

50Hz

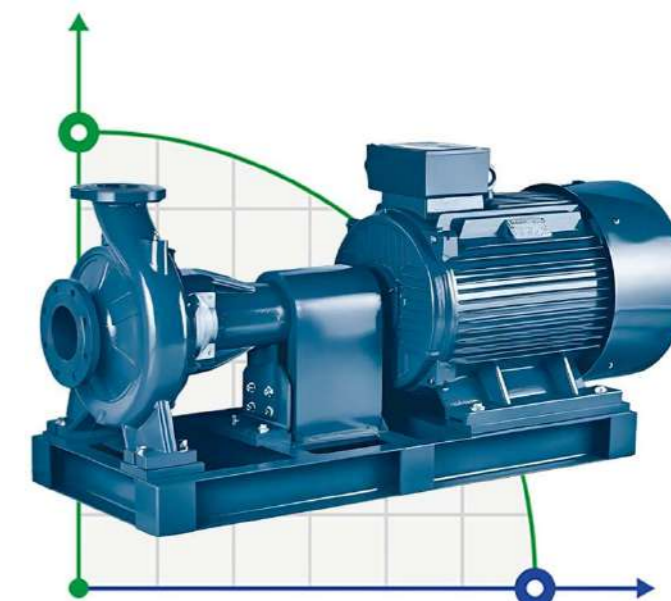

BS/BS4



BSM/BSM4

BS/BS4 End suction centrifugal pump
BS/BS4 Bomba centrífuga de succión final
BS/BS4 Pompe centrifuge aspiration finale

BTS
ENGINEERING

<https://prom-nasos.pro>

<https://bts.net.ua>

<https://prom-nasos.com.ua>

+38 095 656-37-57,

+38 067 360-71-01,

+38 063 362-12-31,

info@prom-nasos.pro

<https://bts.net.ua>



BS



BSM

BS $n \approx 2900$ rpm
End suction centrifugal pump
Bomba centrífuga de succión final
Pompe centrifuge aspiration finale



BSB



BSBM

NEW/NUEVO/NOUVEAU

DESCRIPTION/DESCRIPCIONES/DESCRIPTION

- ◆ Complete range with a full series of end suction pumps
 - ◆ Outstanding reliability for operation in any application
 - ◆ YE3 high efficient motor, with protection IP55 class F
 - ◆ Pump case with anti-corrosive coating
 - ◆ Customize casting logo on the bearing house as request
 - ◆ Quality NSK bearing, wear resistance mechanical seal
- ◆ Gama completa con una serie completa de bombas
 - ◆ Excelente fiabilidad para cualquier aplicación
 - ◆ Motor de eficiencia YE3 con Protección IP55 clase F
 - ◆ Cuerpo de bomba con tratamiento anti-corrosión
 - ◆ Personalizar el logotipo de fundición en la caja como solicitud
 - ◆ Rodamiento de marca NSK y cierre mecánico personalizado
- ◆ Gamme complète avec une série complète de pompes
 - ◆ Fiabilité exceptionnelle pour n'importe quelle application
 - ◆ Moteur haute efficacité YE3, avec protection IP55 classe F
 - ◆ Boîtier de pompe avec revêtement anti-corrosif
 - ◆ Personnalisez le logo de coulée sur le palier comme demande
 - ◆ Roulement NSK qualité, joint mécanique de résistance à l'usure

APPLICATIONS/APLICACIONES/APPLICATIONS

- ◆ The impressive range end-suction pumps is compatible with an array of application areas, including water intake, heating, industrial pressure boosting, industrial liquid transfer, air-conditioning, district cooling, irrigation, fire fighting and many more.
- ◆ La impresionante gama de bombas de succión final es compatible con una variedad de áreas de aplicación, que incluyen la toma de agua, calefacción, aumento de la presión industrial, transferencia de líquido industrial, aire acondicionado, refrigeración urbana, riego, extinción de incendios y muchos más.
- ◆ La gamme impressionnante de pompes à aspiration finale est compatible avec un large éventail de domaines d'application, notamment prise d'eau, chauffage, surpression industrielle, transfert de liquide industriel, climatisation, refroidissement urbain, l'irrigation, lutte contre l'incendie et bien d'autres.

USING LIMITS/LÍMITES UTILIZACIÓN/UTILISATION LIMITES

- ◆ Liquid temperature between -10°C and $+120^{\circ}\text{C}$
 - ◆ Ambient temperature between -10°C and $+50^{\circ}\text{C}$
 - ◆ Max. working pressure **20 bar**
 - ◆ Continuous service **S1**
- ◆ Temperatura del líquido de -10°C hasta $+120^{\circ}\text{C}$
 - ◆ Temperatura ambiente de -10°C hasta $+50^{\circ}\text{C}$
 - ◆ Presión máxima en el cuerpo de la bomba **20 bar**
 - ◆ Funcionamiento continuo **S1**
- ◆ Température du liquide entre -10°C et $+120^{\circ}\text{C}$
 - ◆ Température ambiante entre -10°C et $+50^{\circ}\text{C}$
 - ◆ Max. pression de service **20 bar**
 - ◆ Service continu **S1**

MODEL CODE/CÓDIGO MODELO/CODE MODÈLE

For example/ Por ejemplo/ Par exemple

BS (BSM) 50 - 250 / 220

- ◆ **220**=Rated power(kw)x10
Potencia nominal(kw)x10
Puissance nominale (kw) x10
- ◆ **250**=Nominal impeller size(mm)
Tamaño nominal del impulsor (mm)
Taille nominale de la roue (mm)
- ◆ **250H**=High flow type
Type de caudal grande
Type à haut débit
- ◆ **50**=Discharge/Descarga/Décharge(mm)
- ◆ **BSM**=End suction pump with motor&base
Bomba con motor y base
Pompe avec moteur et base
- ◆ **BSBM**=End suction pump with motor&base
(in type B bearing house)
Bomba con motor y base
(en soporte de rodamiento tipo B)
Pompe avec moteur et base
(dans une maison de roulement de type B)
- ◆ **BS**=End suction pump only
Solo bomba
Pompe uniquement
- ◆ **BSB**=End suction pump only
(in type B bearing house)
Solo bomba
(en soporte de rodamiento tipo B)
Pompe uniquement
(dans une maison de roulement de type B)

TECHNICAL SHEET/HOJA TÉCNICA/FICHE TECHNIQUE

Model/Modelo/Modèle	BS	
Capacity/Caudal/Débit	0-1000	m ³ /h
Head/Altura/Hauteur	0-164	m
DN	32-150	mm
Speed/Velocidad/Vitesse	2900	rpm
T max	120	°C
Power/Potencia/Puiss.	1.5-315	kW
Casing/Cuerpo/Corps	Grey cast iron Hierro fundido gris Fonte grise	
Impeller/Impulsor/Roue	Cast iron/AISI 304/Brass Hierro fundido/Inox304/Bronce Fonte/Inox 304/Laiton	
Shaft/Eje/Arbre	45# steel/AISI 304 45 # acero/Inox304 45 # acier/Inox 304	
Shaft seal/Sello/Scellé	Mechanical Seal Sello mecánico Garniture mécanique	
Bearing/Rodamiento/Palier	Grease lubrication rolling bearing Rodamientos lubricación con grasa Roulement lubrification à la graisse	



BS4 $n \approx 1450$ rpm
End suction centrifugal pump
Bomba centrífuga de succión final
Pompe centrifuge aspiration finale



BS4



BSM4



BSB4



BSBM4

NEW/NUEVO/NOUVEAU

DESCRIPTION/DESCRIPCIONES/DESCRIPTION

- ◆ Complete range with a full series of end suction pumps
 - ◆ Outstanding reliability for operation in any application
 - ◆ YE3 high efficient motor, with protection IP55 class F
 - ◆ Pump case with anti-corrosive coating
 - ◆ Customize casting logo on the bearing house as request
 - ◆ Quality NSK bearing, wear resistance mechanical seal
- ◆ Gama completa con una serie completa de bombas
 - ◆ Excelente fiabilidad para cualquier aplicación
 - ◆ Motor de eficiencia YE3 con Protección IP55 clase F
 - ◆ Cuerpo de bomba con tratamiento anti-corrosión
 - ◆ Personalizar el logotipo de fundición en la caja como solicitud
 - ◆ Rodamiento de marca NSK y cierre mecánico personalizado
- ◆ Gamme complète avec une série complète de pompes
 - ◆ Fiabilité exceptionnelle pour n'importe quelle application
 - ◆ Moteur haute efficacité YE3, avec protection IP55 classe F
 - ◆ Boîtier de pompe avec revêtement anti-corrosif
 - ◆ Personnalisez le logo de coulée sur le palier comme demande
 - ◆ Roulement NSK qualité, joint mécanique de résistance à l'usure

APPLICATIONS/APLICACIONES/APPLICATIONS

- ◆ The impressive range end-suction pumps is compatible with an array of application areas, including water intake, heating, industrial pressure boosting, industrial liquid transfer, air-conditioning, district cooling, irrigation, fire fighting and many more.
- ◆ La impresionante gama de bombas de succión final es compatible con una variedad de áreas de aplicación, que incluyen la toma de agua, calefacción, aumento de la presión industrial, transferencia de líquido industrial, aire acondicionado, refrigeración urbana, riego, extinción de incendios y muchos más.
- ◆ La gamme impressionnante de pompes à aspiration finale est compatible avec un large éventail de domaines d'application, notamment prise d'eau, chauffage, surpression industrielle, transfert de liquide industriel, climatisation, refroidissement urbain, l'irrigation, lutte contre l'incendie et bien d'autres.

USING LIMITS/LÍMITES UTILIZACIÓN/UTILISATION LIMITES

- ◆ Liquid temperature between -10°C and $+120^{\circ}\text{C}$
- ◆ Ambient temperature between -10°C and $+50^{\circ}\text{C}$
- ◆ Max. working pressure **16 bar**
- ◆ Continuous service **S1**
- ◆ Temperatura del líquido de -10°C hasta $+120^{\circ}\text{C}$
- ◆ Temperatura ambiente de -10°C hasta $+50^{\circ}\text{C}$
- ◆ Presión máxima en el cuerpo de la bomba **16 bar**
- ◆ Funcionamiento continuo **S1**
- ◆ Température du liquide entre -10°C et $+120^{\circ}\text{C}$
- ◆ Température ambiante entre -10°C et $+50^{\circ}\text{C}$
- ◆ Max. pression de service **16 bar**
- ◆ Service continu **S1**

MODEL CODE/CÓDIGO MODELO/CODE MODÈLE

For example/ Por ejemplo/ Par exemple

BS4 (BSM4) 100 - 250 / 75

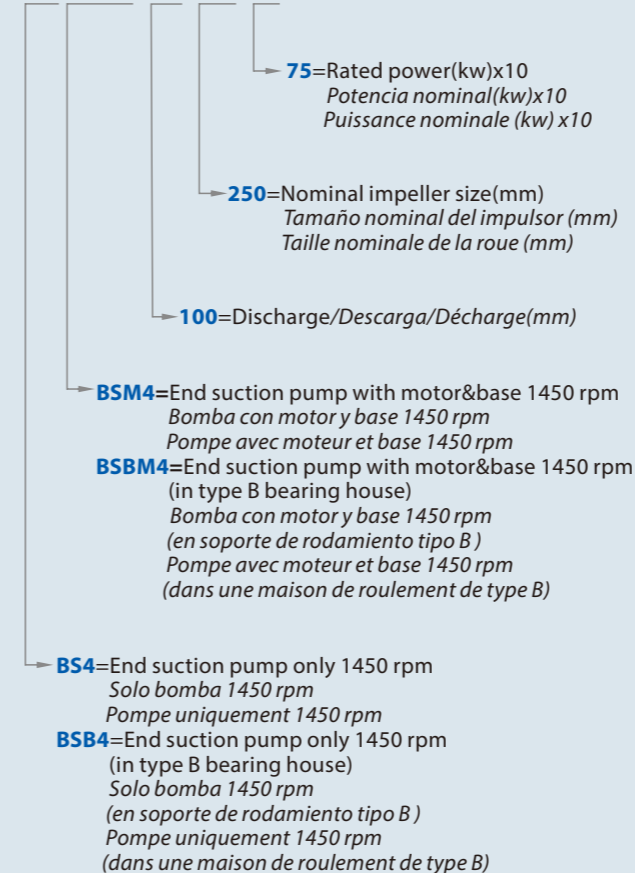

TECHNICAL SHEET/HOJA TÉCNICA/FICHE TECHNIQUE

Model/Modelo/Modèle	BS4	
Capacity/Caudal/Débit	0-1500	m ³ /h
Head/Altura/Hauteur	0-72	m
DN	65-250	mm
Speed/Velocidad/Vitesse	1450	rpm
T max	120	°C
Power/Potencia/Puiss.	1.1-250	kW
Casing/Cuerpo/Corps	Grey cast iron Hierro fundido gris Fonte grise	
Impeller/Impulsor/Roue	Cast iron/AISI 304/Brass Hierro fundido /Inox304/Bronce Fonte /Inox 304 /Laiton	
Shaft/Eje/Arbre	45# steel/AISI304 45 # acero/Inox304 45 # acier/Inox304	
Shaft seal/Sello/Scellé	Mechanical Seal Sello mecánico Garniture mécanique	
Bearing/Rodamiento/Palier	Grease lubrication rolling bearing Rodamientos lubricación con grasa Roulement lubrification à la graisse	

MATERIAL DESCRIPTION/DESCRIBCIÓN DE MATERIAL/DESCRIPTION DU MATÉRIEL

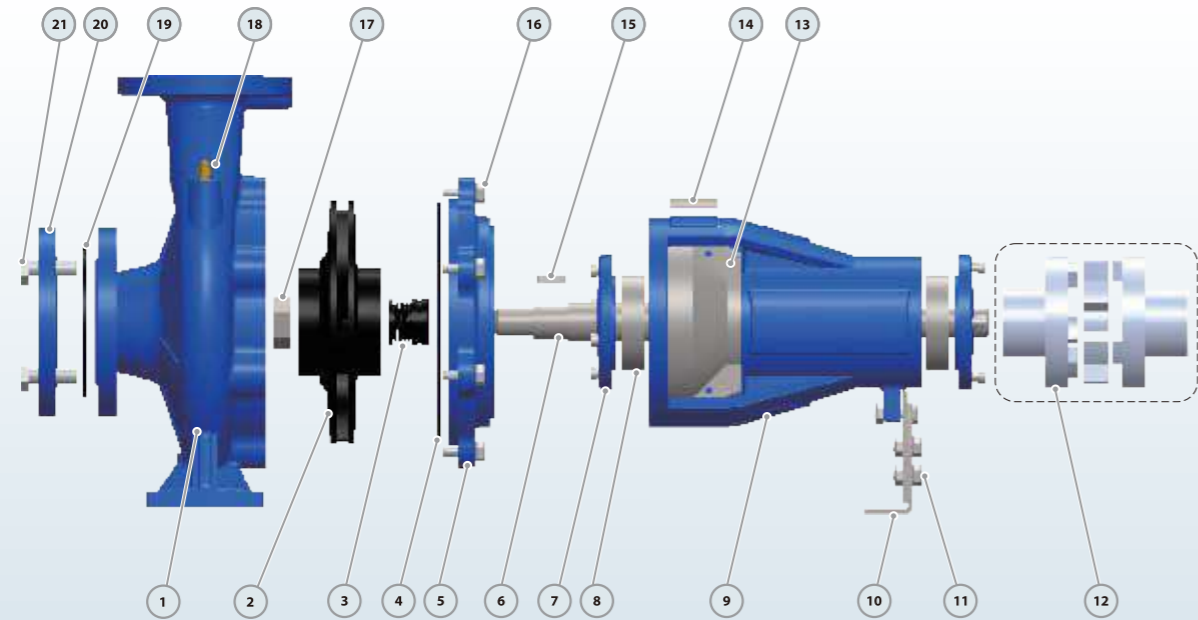

No.	Description Descripción Description	Material Material Matériel	No.	Description Descripción Description	Material Material Matériel	No.	Description Descripción Description	Material Material Matériel
1	Pump Case Cuerpo de Bomba Boîtier de pompe	Cast iron Fundición Fonte	8	Bearing Rodamiento Palier	Ball Bearing Bola Rodamiento Roulement à billes	15	Impeller Key Chaveta Impulsor Clé de roue	Iron Hierro Le fer
2	Impeller Impulsor Roue	SS304/Cast iron Inox304/Fundición Inox304 / Fonte	9	Support Case Cuerpo Soporte Cas de support	Cast iron Fundición Fonte	16	Connection Bolt Perno Boulon de connexion	Steel Acero Acier
3	Mechanical Seal Cierre Mecánico Garniture mécanique	SiC/Carbon/SS304 SiC/Grafito/Inox304 SiC/Carbon/Inox304	10	Support Foot Soporte Pie Pied de support	Iron Hierro Le fer	17	Impeller Nut Tuerca de Impulsor Écrou de roue	Galvanized Steel Acero Galvanizado Acier Galvanisé
4	O-ring Junta Tórica Joint torique	Rubber Caucho Caoutchouc	11	Foot Bolt Perno Boulon de pied	Steel Acero Acier	18	Release Valve Tapón Cebado Soupape de décharge	Brass Bronce Laiton
5	Connection Conexión Lien	Cast iron Fundición Fonte	12	Coupling(Optional) Unión(Opcional) Accouplement (facultatif)	Steel Acero Acier	19	Gasket Empaque Joint	Rubber Caucho Caoutchouc
6	Shaft Eje Arbre	SS304/45# Steel Inox304/45# Hierro Acier Inox304/ 45 #	13	Case Cover Tapa Cuerpo Housse de protection	SS304 Inox304 Inox304	20	Counter Flange Contra Brida Contre bride	Galvanized Cast iron Fundición Galvanizado Fonte Galvanisée
7	Bearing Cover Tapa Rodamiento Couvercle de palier	Cast iron Fundición Fonte	14	Nameplate Letrero Plaque signalétique	Aluminum Aluminio Aluminium	21	Flange Bolt Perno de Brida Boulon à bride	Steel Acero Acier

DIMENSIONS AND WEIGHT/DIMENSIONES Y PESOS/DIMENSIONS ET POIDS

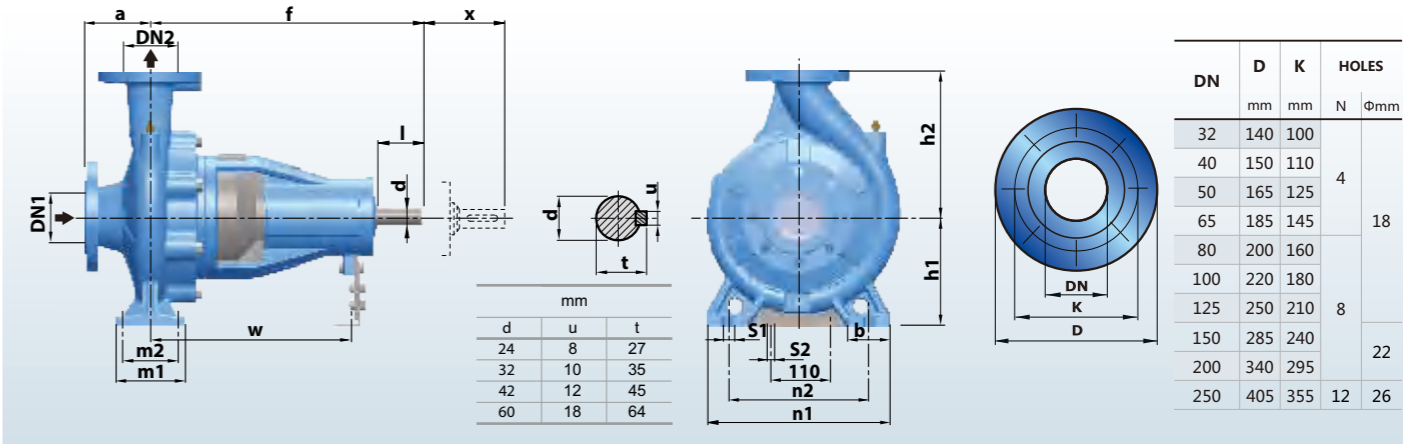

MODEL MODELO MODÈLE	DIMENSIONS/DIMENSIONES/DIMENSIONS mm																kg 3~	
	DN1	DN2	a	f	h1	h2	b	m1	m2	n1	n2	s1	s2	w	x	d		l
32-160	50	32	80	360	132	160	55	95	70	240	190	14	14	260	100	24	50	31
32-200	50	32	80	360	160	180	55	95	70	240	190	14	14	260	100	24	50	35
32-250	50	32	80	360	160	180	55	95	70	240	190	14	14	260	100	24	50	35
40-160	65	40	80	360	132	160	50	100	70	240	190	14	14	260	100	24	50	35
40-200	65	40	100	360	160	180	55	100	70	265	212	14	14	260	100	24	50	38
40-250	65	40	100	360	180	225	65	125	95	320	250	14	14	260	100	24	50	58
40-315	65	40	125	500	200	160	65	125	95	345	280	14	14	370	140	32	80	82
50-125	65	50	100	360	132	180	50	100	70	240	190	14	14	260	100	24	50	30
50-160	65	50	100	360	160	200	55	100	70	265	212	14	14	260	100	24	50	35
50-200	65	50	100	360	160	225	50	100	70	265	212	14	14	260	100	24	50	45
50-250	65	50	100	360	180	180	65	125	95	320	250	14	14	260	100	24	50	50
50-315	65	50	125	500	225	280	65	125	95	345	280	14	14	370	140	32	80	90
65-125	80	65	100	360	160	250	65	125	95	280	212	14	14	260	100	24	50	42
65-160	80	65	100	360	160	200	65	125	95	280	212	14	14	260	100	24	50	45
65-200	80	65	100	360	180	225	65	125	95	320	250	14	14	260	140	24	50	50
65-250	80	65	100	470	200	250	80	160	120	360	280	18	14	340	140	32	80	71
65-315	80	65	125	470	225	280	80	160	120	360	280	18	14	340	140	32	80	98
80-125	100	80	100	360	180	225	65	125	95	320	250	14	14	260	140	24	50	46
80-160	100	80	100	360	180	225	65	125	95	345	250	14	14	260	140	24	50	48
80-200	100	80	100	470	200	250	65	125	95	345	280	14	14	340	140	32	80	65
80-250	100	80	100	470	200	280	80	160	120	400	315	18	14	340	140	32	80	79
80-315	100	80	125	470	250	315	80	160	120	400	315	18	14	340	140	24	50	118
80-400	100	80	125	540	280	355	80	160	120	400	315	18	14	340	140	32	80	150
100-160	125	100	125	360	200	280	80	160	120	360	280	18	14	260	140	32	80	55
100-200	125	100	125	470	200	280	80	160	120	360	280	18	14	340	140	32	80	75
100-250	125	100	125	470	225	280	80	160	120	400	315	18	14	340	140	32	80	88
100-315	125	100	140	470	250	315	80	160	120	400	315	19	14	340	140	32	80	116
100-400	125	100	140	530	280	355	100	200	150	500	400	23	14	370	140	42	110	178
125-200	150	125	140	470	250	315	80	160	120	400	315	19	14	340	140	32	80	112
125-250	150	125	140	470	250	355	80	160	120	400	315	19	14	340	140	32	80	112
125-250H	150	125	140	530	250	355	80	160	120	400	315	19	14	370	140	42	110	140
125-315	150	125	140	530	280	355	100	200	150	500	400	23	14	370	140	42	110	152
125-400	150	125	140	530	315	400	100	200	150	500	400	23	14	370	140	42	110	200
150-200	200	150	160	470	280	400	100	200	150	550	450	23	14	370	140	32	80	166
150-250	200	150	160	530	280	400	100	200	150	550	450	23	14	370	140	42	110	180
150-315	200	150	160	530	280	400	100	200	150	550	450	23	14	370	140	42	110	186
150-400	200	150	160	530	315	450	100	200	150	550	450	23	14	370	140	42	110	228
200-250	250	200	180	530	355	475	100	200	150	550	450	23	14	370	200	42	110	230
200-315	250	200	180	530	355	450	100	200	150	550	450	23	14	370	200	42	110	234
200-400	250	200	180	770	400	500	110	300	250	710	600	28	14	525	250	60	140	363
250-315	300	250	250	530	400	500	110	300	250	710	600	28	14	525	250	42	110	316
250-400	300	250	250	770	400	560	110	300	250	710	600	28	14	525	250	60	140	400



YE3

Electric motor TEFC type
Motor eléctrico tipo TEFC
Moteur électrique type TEFC

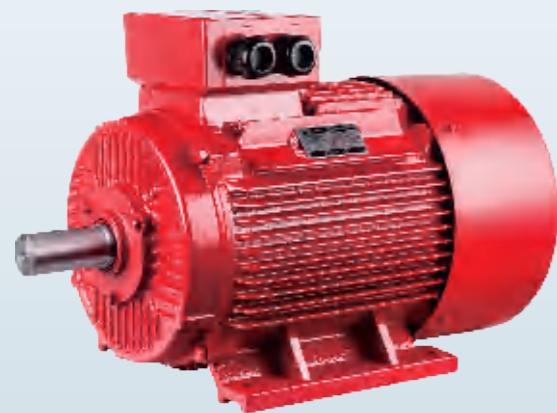

NEW/NUEVO/NOUVEAU

DESCRIBTION/DESCRIPCIONES/DESCRIPTION

- ◆ Design according to IEC60034 standard
 - ◆ TOTAL ENCLOSED FAN COOLING TYPE motor
 - ◆ YE3 high efficient motor
 - ◆ Protection IP55 class F
 - ◆ Quality NSK bearing
 - ◆ Continuous duty S1
 - ◆ Reliable used for fire fighting system etc.
 - ◆ Ambient temperature up to +50°C
 - ◆ Cooling type : IC411
- ◆ *Diseño de acuerdo con el estándar IEC60034*
 - ◆ *TOTAL DE VENTILADOR CERRADO TIPO motor*
 - ◆ *Motor de alta eficiencia YE3*
 - ◆ *Protección IP55 clase F*
 - ◆ *Rodamiento NSK de calidad*
 - ◆ *Servicio continuo S1*
 - ◆ *Fiable utilizado para el sistema de contra incendios, etc.*
 - ◆ *Temperatura ambiente hasta + 50 °C*
 - ◆ *Tipo de enfriamiento: IC411*
- ◆ *Conception selon la norme IEC60034*
 - ◆ *TOTAL REFROIDISSEMENT PAR VENTILATEUR MOTEUR TYPE*
 - ◆ *Moteur haute efficacité YE3*
 - ◆ *Protection IP55 classe F*
 - ◆ *Roulement NSK de qualité*
 - ◆ *Service continu S1*
 - ◆ *Fiable utilisé pour le système de lutte contre l'incendie, etc.*
 - ◆ *Température ambiante jusqu'à + 50 °C*
 - ◆ *Type de refroidissement: IC411*

MODEL CODE/CÓDIGO MODELO/CODE MODÈLE

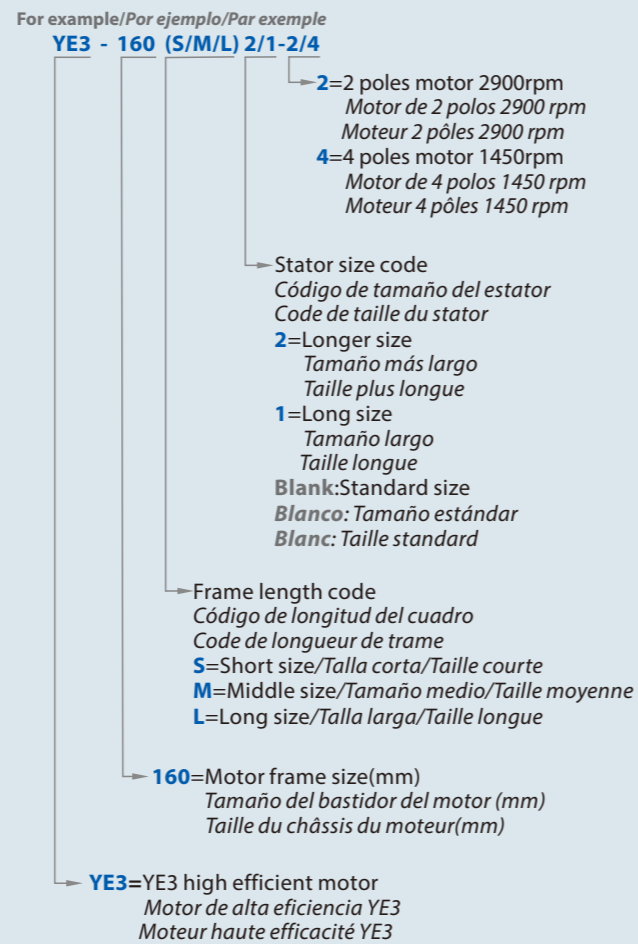

TECHNICAL DATA/DATOS TÉCNICOS/DONNÉES TECHNIQUES

50 Hz n=2900 1/min

MODEL MODELO MODÈLE	Power Potencia Puissance		RPM 1/min	η			cos Φ	A			Nm	Ts/Tn	Tmax/Tn	Is/In	dB(A)	Kgs
	kw	hp		%	75%	50%		380V	400V	415V						
YE3-801-2	0.75	1	2880	80.7	80.7	79.1	0.82	1.72	1.64	1.58	2.49	2.3	2.3	7	73	18.1
YE3-802-2	1.1	1.5	2880	82.7	82.7	81	0.83	2.43	2.31	2.23	3.65	2.2	2.3	7.3	73	19.5
YE3-90S-2	1.5	2	2895	84.2	84.2	82.5	0.84	3.22	3.06	2.95	4.95	2.2	2.3	7.6	76	23.3
YE3-90L-2	2.2	3	2895	85.9	85.9	84.2	0.85	4.58	4.35	4.19	7.26	2.2	2.3	7.6	77	27.1
YE3-100L-2	3	4	2895	87.1	87.1	85.4	0.87	6.02	5.71	5.51	9.9	2.2	2.3	7.8	79	38.8
YE3-112M-2	4	5.5	2905	88.1	88.1	86.3	0.88	7.84	7.45	7.18	13.1	2.2	2.3	8.3	80	48.3
YE3-132S1-2	5.5	7.5	2930	89.2	89.2	87.4	0.88	10.6	10.1	9.75	17.9	2	2.3	8.3	83	55.1
YE3-132S2-2	7.5	10	2930	90.1	90.1	88.3	0.88	14.4	13.7	13.2	24.4	2	2.3	7.9	84	69.2
YE3-160M1-2	11	15	2945	91.2	91.2	89.4	0.89	20.6	19.6	18.9	35.7	2	2.3	8.1	87	113
YE3-160M2-2	15	20	2945	91.9	91.9	90.1	0.89	27.9	26.5	25.5	48.6	2	2.3	8.1	87	123
YE3-160L-2	18.5	25	2940	92.4	92.4	90.6	0.89	34.2	32.5	31.3	60.1	2	2.3	8.2	90	142
YE3-180M-2	22	30	2955	92.7	92.7	90.8	0.89	40.5	38.5	37.1	71.1	2	2.3	8.2	90	182
YE3-200L1-2	30	40	2960	93.3	93.3	91.4	0.89	54.9	52.1	50.3	96.8	2	2.3	7.6	91	246
YE3-200L2-2	37	50	2960	93.7	93.7	91.8	0.89	67.4	64	61.7	119.4	2	2.3	7.6	91	265
YE3-225M-2	45	60	2965	94	94	92.1	0.9	80.8	76.8	74	144.9	2	2.3	7.7	93	323
YE3-250M-2	55	75	2970	94.3	94.3	92.4	0.9	98.5	93.5	90.2	176.9	2	2.3	7.7	93	413
YE3-280S-2	75	100	2975	94.7	94.7	92.8	0.9	134	127	122	240.8	1.8	2.3	7.1	94	546
YE3-280M-2	90	125	2975	95	95	93.1	0.9	160	152	146	288.9	1.8	2.3	7.1	94	569
YE3-315S-2	110	150	2978	95.2	95.2	93.3	0.9	195	185	179	352.8	1.8	2.3	7.1	94	897
YE3-315M-2	132	180	2978	95.4	95.4	93.5	0.9	234	222	214	423.3	1.8	2.3	7.1	95	1029
YE3-315L1-2	160	220	2980	95.6	95.6	93.7	0.91	279	265	256	512.8	1.8	2.3	7.2	95	1067
YE3-315L2-2	200	270	2980	95.8	95.8	93.9	0.91	349	331	319	640.9	1.8	2.2	7.2	95	1194
YE3-355M-2	250	340	2982	95.8	95.8	93.9	0.91	436	414	399	800.6	1.6	2.2	7.2	103	1685
YE3-355L-2	315	430	2982	95.8	95.8	93.9	0.91	549	522	503	1009	1.6	2.2	7.2	103	1734

50 Hz n=1450 1/min

MODEL MODELO MODÈLE	Power Potencia Puissance		RPM 1/min	η			cos Φ	A			Nm	Ts/Tn	Tmax/Tn	Is/In	dB(A)	Kgs
	kw	hp		%	75%	50%		380V	400V	415V						
YE3-801-4	0.55	0.75	1400	80.8	80.8	79.2	0.75	1.38	1.31	1.26	3.75	2.4	2.3	5.2	63	17.6
YE3-802-4	0.75	1	1420	82.5	82.5	80.9	0.75	1.84	1.75	1.69	5.04	2.3	2.3	6.6	63	18.4
YE3-90S-4	1.1	1.5	1445	84.1	84.1	82.4	0.76	2.61	2.48	2.39	7.27	2.3	2.3	6.8	66	24.2
YE3-90L-4	1.5	2	1445	85.3	85.3	83.6	0.77	3.47	3.3	3.18	9.91	2.3	2.3	7	66	29.7
YE3-100L1-4	2.2	3	1450	86.7	86.7	85	0.81	4.76	4.52	4.36	14.6	2.3	2.3	7.6	68	41.5
YE3-100L2-4	3	4	1450	87.7	87.7	85.9	0.82	6.34	6.02	5.8	20	2.3	2.3	7.6	68	46
YE3-112M-4	4	5.5	1450	88.6	88.6	86.8	0.82	8.37	7.95	7.66	26.5	2.2	2.3	7.8	72	63.2
YE3-132S-4	5.5	7.5	1460	89.6	89.6	87.8	0.83	11.2	10.7	10.3	36	2	2.3	7.9	74	71.2
YE3-132M-4	7.5	10	1460	90.4	90.4	88.6	0.84	15	14.3	13.7	49.1	2	2.3	7.5	77	85.1
YE3-160M-4	11	15	1465	91.4	91.4	89.6	0.85	21.5	20.4	19.7	71.7	2.2	2.3	7.7	78	121
YE3-160L-4	15	20	1465	92.1	92.1	90.3	0.86	28.8	27.3	26.3	97.8	2.2	2.3	7.8	82	142
YE3-180M-4	18.5	25	1470	92.6	92.6	90.7	0.86	35.3	33.5	32.3	120.2	2	2.3	7.8	82	181
YE3-180L-4	22	30	1470	93	93	91.1	0.86	41.8	39.7	38.3	142.9	2	2.3	7.8	82	209
YE3-200L-4	30	40	1475	93.6	93.6	91.7	0.86	56.6	53.8	51.8	194.2	2	2.3	7.3	84	284
YE3-225S-4	37	50	1485	93.9	93.9	92	0.86	69.6	66.1	63.7	237.9	2	2.3	7.4	85	328
YE3-225M-4	45	60	1485	94.2	94.2	92.3	0.86	84.4	80.2	77.3	289.4	2	2.3	7.4	86	363
YE3-250M-4	55	75	1485	94.6	94.6	92.7	0.86	103	97.6	94.1	353.7	2.2	2.3	7.4	86	442
YE3-280S-4	75	100	1486	95	95	93.1	0.88	136	139	125	482	2	2.3	6.9	89	569
YE3-280M-4	90	125	1486	95.2	95.2	93.3	0.88	163	155	149	578.4	2	2.3	6.9	89	639
YE3-315S-4	110	150	1488	95.4	95.4	93.5	0.89	197	187	180	706	2	2.2	7	89	939
YE3-315M-4	132	180	1488	95.6	95.6	93.7	0.89	236	224	216	847.2	2	2.2	7	92	1033
YE3-315L1-4	160	220	1488	95.8	95.8	93.9	0.89	285	271	261	1027	2	2.2	7.1	92	1126
YE3-315L2-4	200	270	1490	96	96	94.1	0.9	352	334	322	1282	2	2.2	7.1	92	1238
YE3-355M-4	250	340	1490	96	96	94.1	0.9	440	418	403	1602	2	2.2	7.1	101	1830
YE3-355L-4	315	430	1490	96	96	94.1	0.9	554	526	507	2019	2	2.2	7.1	101	1950

MATERIAL DESCRIPTION/DESCRIBCIÓN DE MATERIAL/DESCRIPTION DU MATÉRIEL

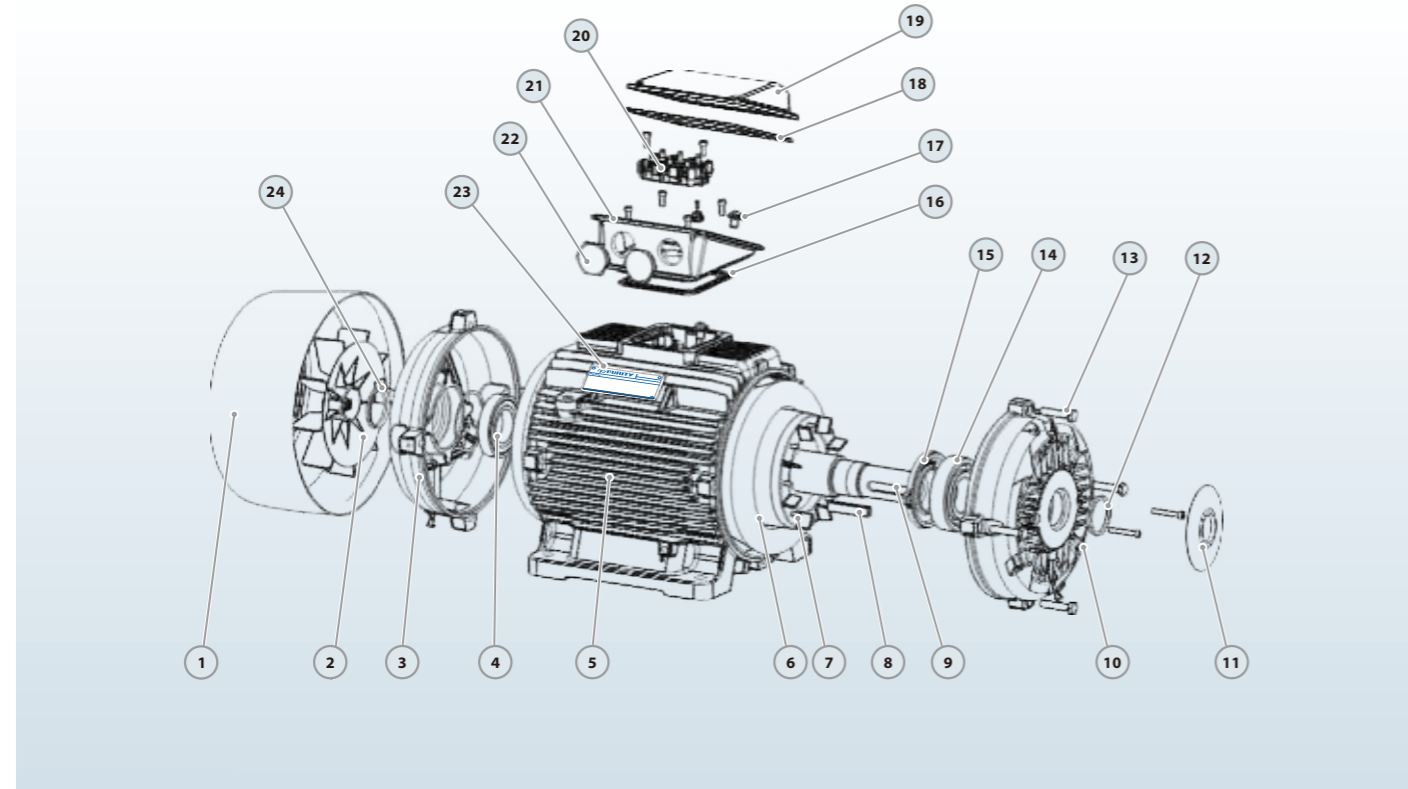

No.	Description Descripción Description	Material Material Matériel	No.	Description Descripción Description	Material Material Matériel	No.	Description Descripción Description	Material Material Matériel
1	Fan cover Tapa ventilador Capot de ventilateur	Iron Hierro Le fer	9	Shaft Eje Arbre	45# Steel 45# Hierro 45 # Acier	17	Screw Tornillo Vis	Steel Acero Acier
2	Fan Ventilador Ventilateur	Plastic Plástico Plastique	10	Front endshield Escudo frontal Pare-brise avant	Cast iron Fundición Fonte	18	Gasket Empaquetadura Joint	Rubber Caucho Caoutchouc
3	Rear endshield Escudo trasero Pare-brise arrière	Cast iron Fundición Fonte	11	Bearing cap Tapa de rodamiento Capuchon de roulement	Cast iron Fundición Fonte	19	Terminal box cover Tapa de la caja Couvercle de boîte à bornes	Aluminum Aluminio Aluminium
4	Rear bearing Rodamiento trasero Roulement arrière	Ball Bearing Bola Rodamiento Roulement à billes	12	Seal Sello Joint	Rubber Caucho Caoutchouc	20	Terminal board Tablero de terminales Bornier	Plastic Plástico Plastique
5	Frame Marco Cadre	Cast iron Fundición Fonte	13	Bolt Tornillo Boulon	Steel Acero Acier	21	Terminal box Caja de terminales Boîte à bornes	Aluminum Aluminio Aluminium
6	Wound Stator Estator herido Stator de blessure	Silicon Steel/Copper Acero al Silicio/Cobre Acier au silicium / cuivre	14	Front bearing Rodamiento delantero Roulement avant	Ball Bearing Bola Rodamiento Roulement à billes	22	Terminal box plug Enchufe de la caja Fiche de boîte à bornes	Plastic Plástico Plastique
7	Rotor Rotor Rotor	Silicon Steel Acero al Silicio Acier au silicium	15	Internal bearing cap Tapa interna de rodamiento Chapeau de palier interne	Cast iron Fundición Fonte	23	Nameplate Placa de nombre Plaque signalétique	Aluminum Aluminio Aluminium
8	Key Llave Clé	Iron Hierro Le fer	16	Gasket Empaquetadura Joint	Rubber Caucho Caoutchouc	24	Seal Sello Scellé	Rubber Caucho Caoutchouc

DIMENSIONS/DIMENSIONES/DIMENSIONS

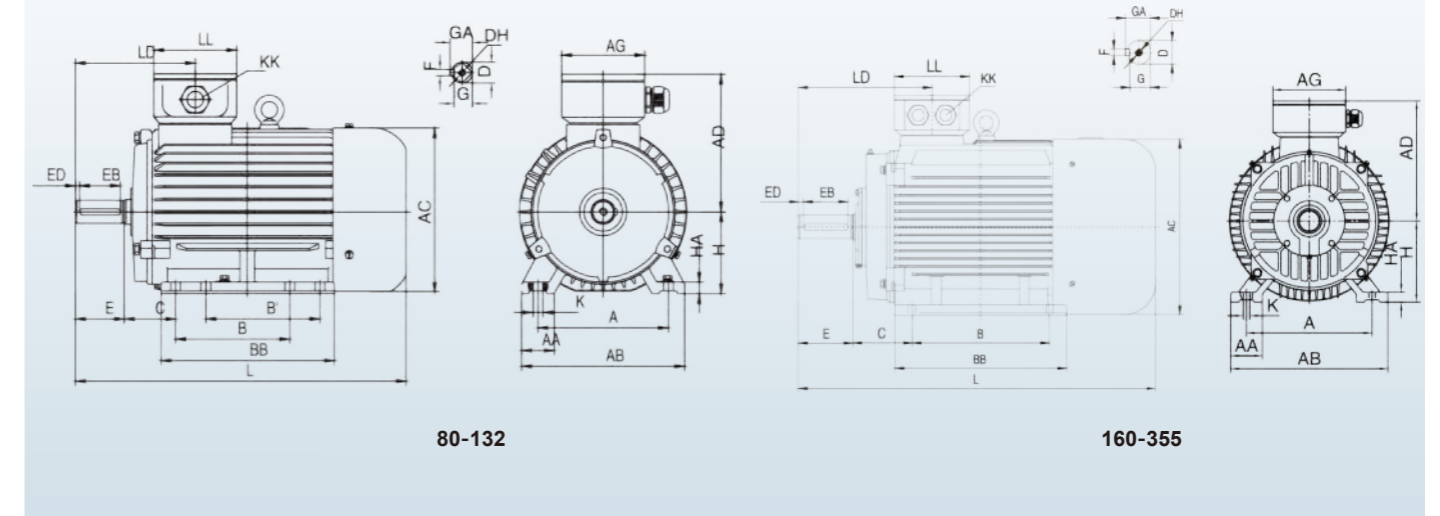

MODEL MODELO MODÈLE	DIMENSIONS/DIMENSIONES/DIMENSIONS mm																							
	A	AA	AB	AC	AD	AG	B	BB	C	D	DH	E	EB	ED	F	G	GA	H	HA	K	KK	L	LD	LL
80	125	34	160	167	147	102	100	150	50	19	M6X16	40	30	2.5	6	15.5	21.5	80	10	4-Φ10	1-M25X1.5	304	119	102
90S	140	36	176	182.4	154.5	102	100	161	56	24	M8X19	50	40	5	8	20	27	90	12	4-Φ10	1-M25X1.5	336	143	102
90L	140	36	176	182.4	154.5	102	125	186	56	24	M8X19	50	40	5	8	20	27	90	12	4-Φ10	1-M25X1.5	361	143	102
100L	160	40	200	205.4	166	102	140	213	63	28	M10X22	60	50	5	8	24	31	100	14	4-Φ12	1-M32X1.5	406	147	102
112M	190	50	240	230	188	118	140	188	70	28	M10X22	60	50	5	8	24	31	112	15	4-Φ12	2-M32X1.5	394	147	110
132S	216	55	265	258.4	203	118	140	186	89	38	M12X28	80	65	5	10	33	41	132	18	4-Φ12	2-M32X1.5	438	172	110
132M	216	55	265	258.4	203	118	178	224	89	38	M12X28	80	65	7.5	10	33	41	132	18	4-Φ12	2-M32X1.5	476	172	110
160M	254	65	314	314	251	162	210	260	108	42	M16X36	110	90	7.5	12	37	45	160	20	4-Φ14.5	2-M40X1.5	608	256	152
160L	254	65	314	314	251	162	254	304	108	42	M16X36	110	90	10	12	37	45	160	20	4-Φ14.5	2-M40X1.5	652	256	152
180M	279	70	349	355	267	162	241	311	121	48	M16X36	110	90	10	14	42.5	51.5	180	22	4-Φ14.5	2-M40X1.5	688	271	152
180L	279	70	349	355	267	162	279	349	121	48	M16X36	110	90	10	14	42.5	51.5	180	22	4-Φ14.5	2-M40X1.5	726	271	152
200L	318	70	388	397	299	210	305	369	133	55	M20X42	110	100	10	16	49	59	200	25	4-Φ18.5	2-M50X1.5	779	296	190
225S	356	75	431	446	322	210	286	368	149	60	M20X42	140	125	5	18	53	64	225	28	4-Φ18.5	2-M50X1.5	824	329	190
225M	356	75	431	446	322	210	311	393	149	55	M20X42	110	100	7.5	16	49	59	225	28	4-Φ18.5	2-M50X1.5	819	299	190
250M	406	80	484	485	358	248	349	445	168	60	M20X42	140	125	7.5	18	53	64	250	30	4-Φ24	2-M63X1.5	910	347	218
280S	457	85	542	547	387	248	368	485	190	65	M20X42	140	125	7.5	18	58	69	280	35	4-Φ24	2-M63X1.5	982	355.5	218
280M	457	85	542	547	387	248	419	536	190	65	M20X42	140	125	7.5	18	58	69	280	35	4-Φ24	2-M63X1.5	1033	355.5	218
315S	508	120	628	620	527	320	406	570	216	65	M20X42	140	125	7.5	18	58	69	315	45	4-Φ28	2-M63X1.5	1194	397	280
315M	508	120	628	620	527	320	457	680	216	65	M20X42	140	125	7.5	18	58	69	315	45	4-Φ28	2-M63X1.5	1304	397	280
315L	508	120	628	620	527	320	508	680	216	65	M20X42	140	125	7.5	18	58	69	315	45	4-Φ28	2-M63X1.5	1304	397	280
355M	610	116	726	698	642	380	560	750	254	75	M20X42	140	130	5	20	67.5	79.5	355	52	6-Φ28	2-M63X1.5	1486	414	330
355L	610	116	726	698	642	380	630	750	254	75	M20X42	140	130	5	20	67.5	79.5	355	52	6-Φ28	2-M63X1.5	1486	414	330

32-160

2900rpm

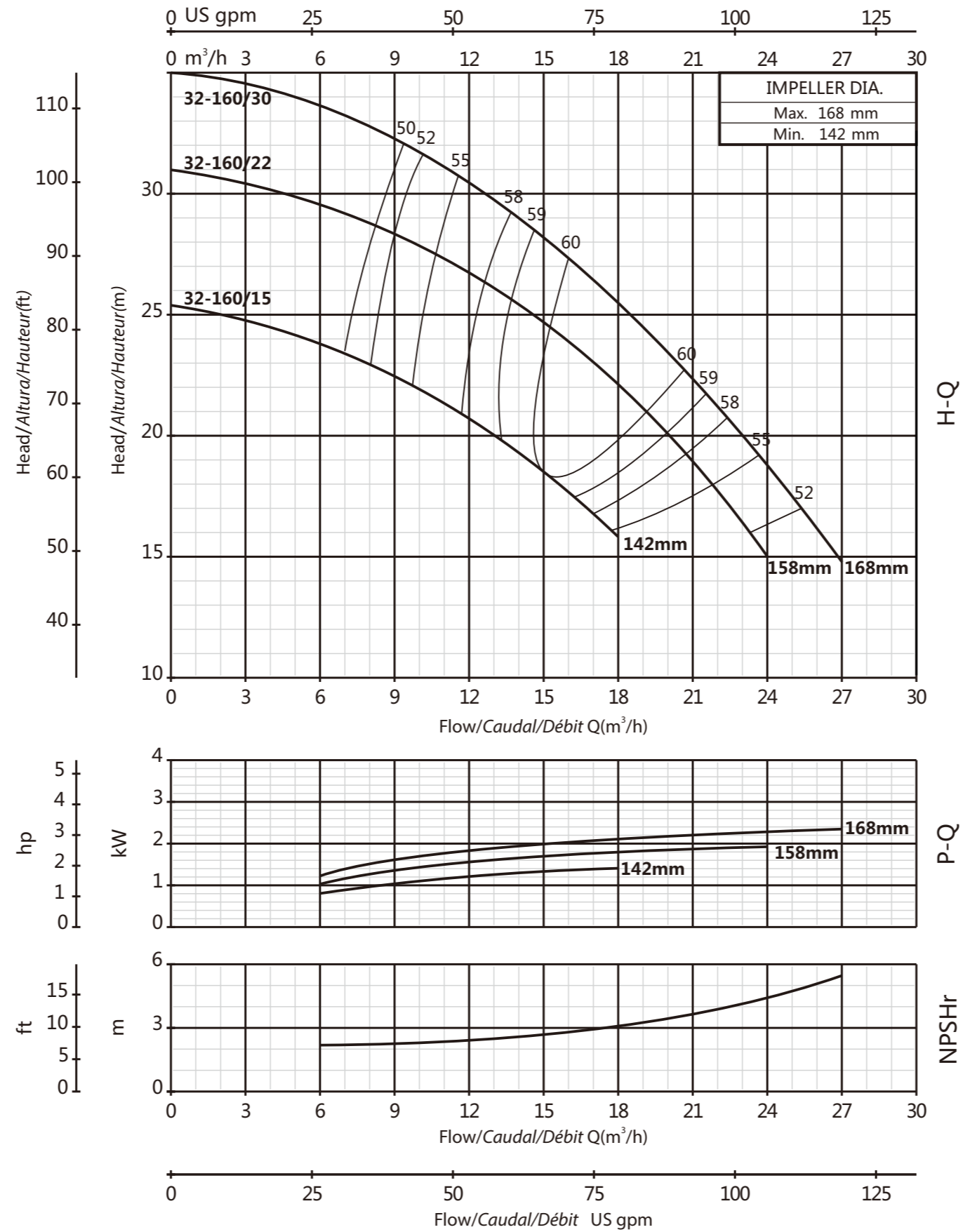

PERFORMANCE CURVE/CURVA DE RENDIMIENTO/COURBE DE PERFORMANCE

32-200

2900rpm

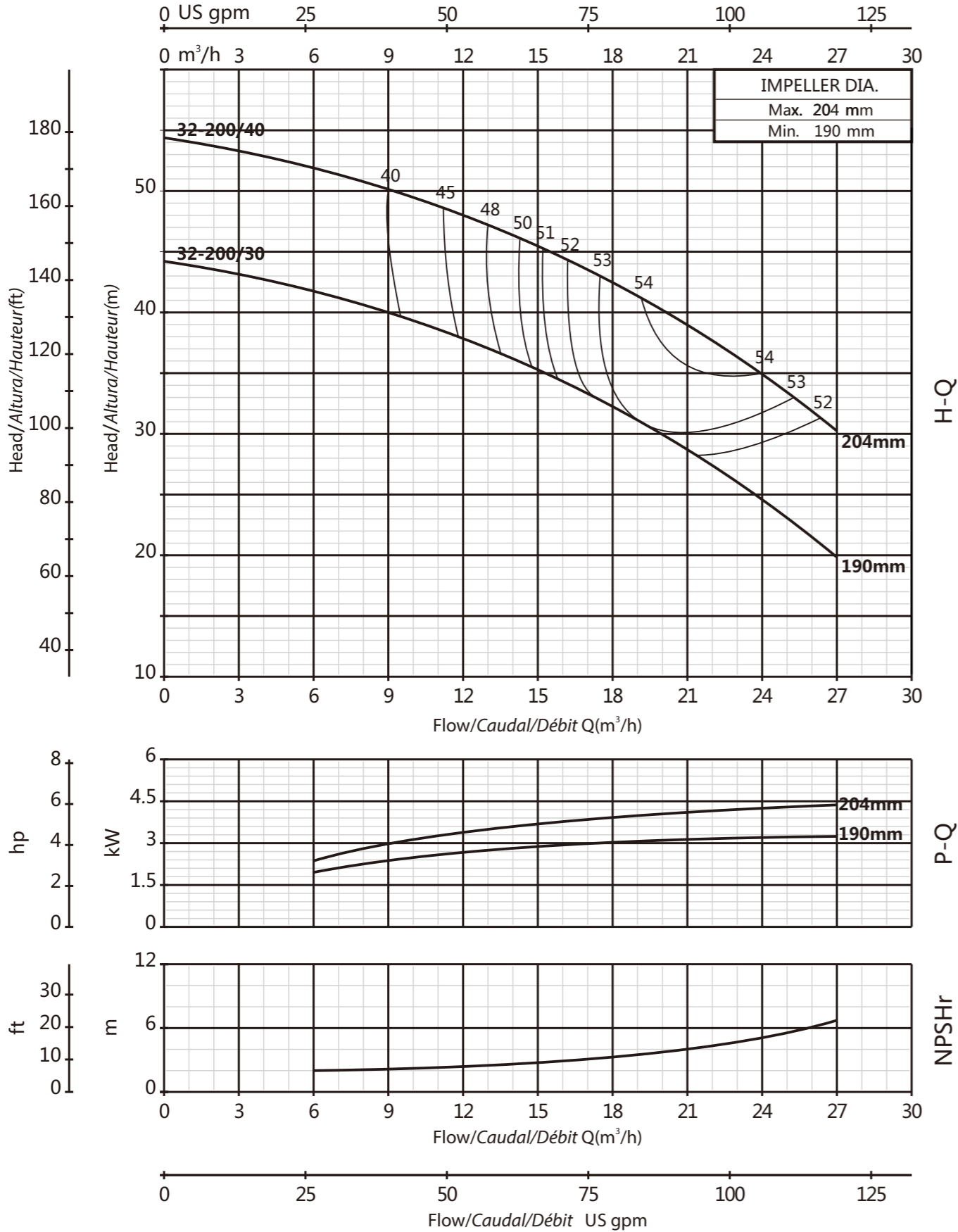

32-250

2900rpm

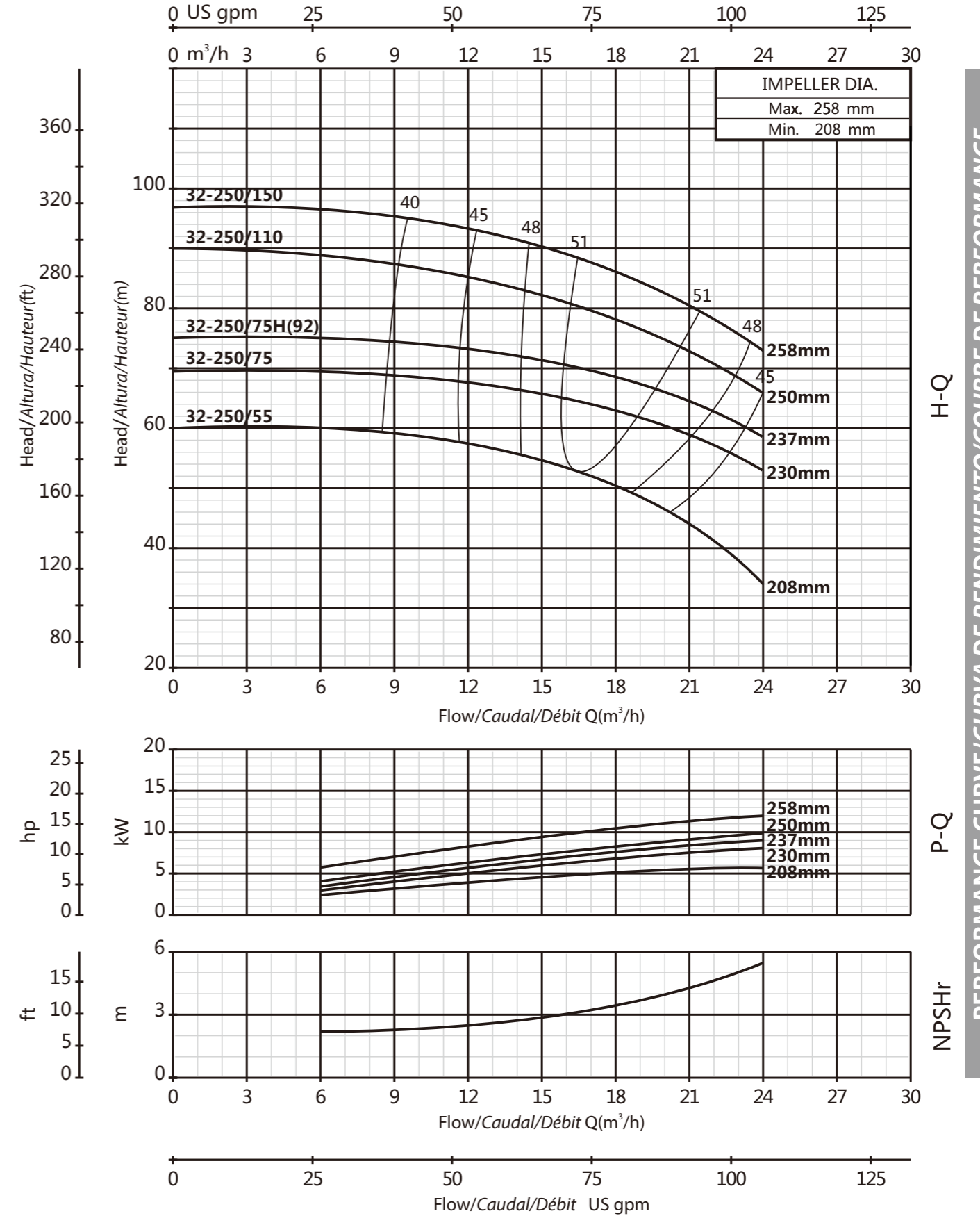

PERFORMANCE CURVE/CURVA DE RENDIMIENTO/COURBE DE PERFORMANCE

PERFORMANCE CURVE/CURVA DE RENDIMIENTO/COURBE DE PERFORMANCE

40-160

2900rpm

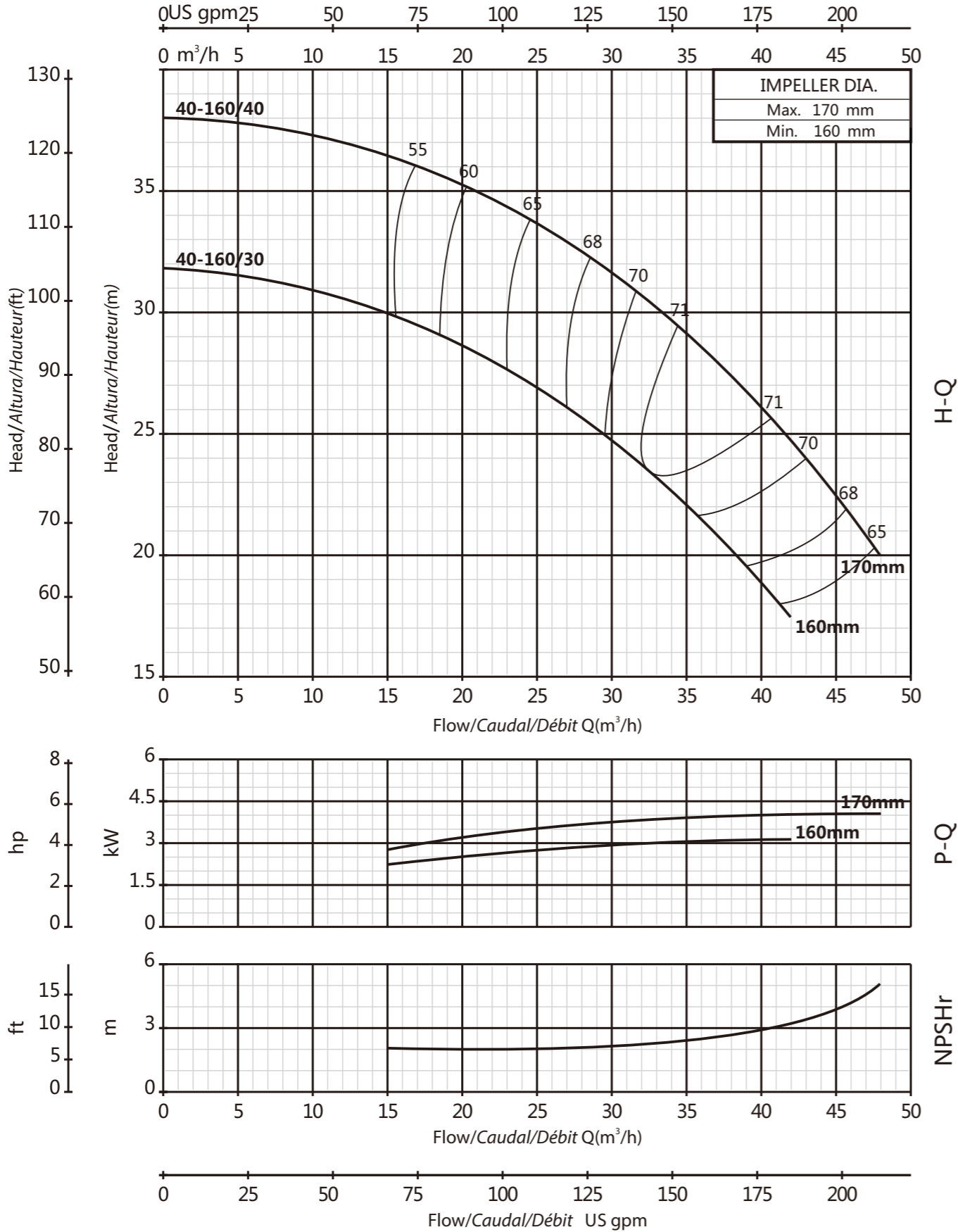

40-200

2900rpm

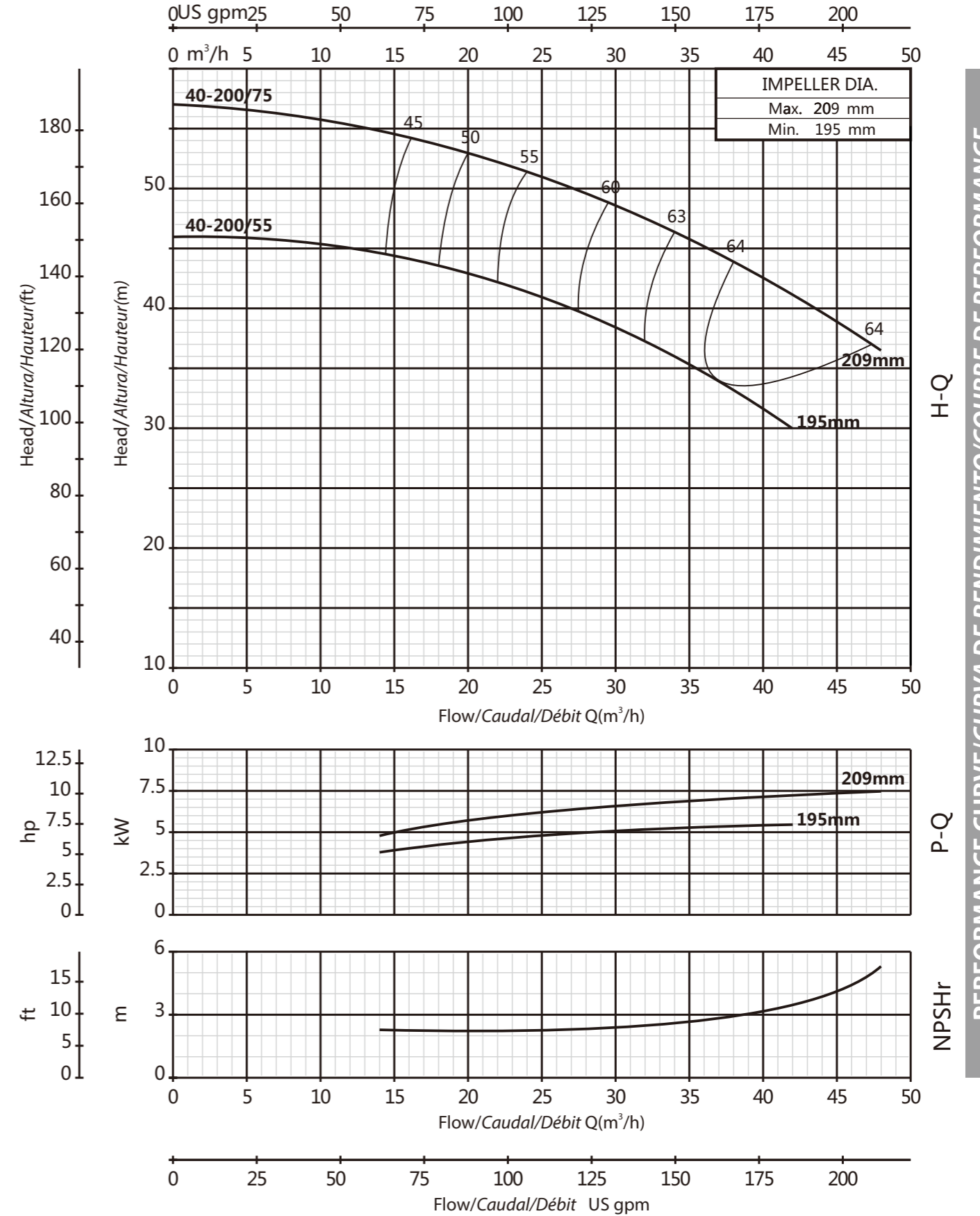

PERFORMANCE CURVE/CURVA DE RENDIMIENTO/COURBE DE PERFORMANCE

PERFORMANCE CURVE/CURVA DE RENDIMIENTO/COURBE DE PERFORMANCE

40-250

2900rpm

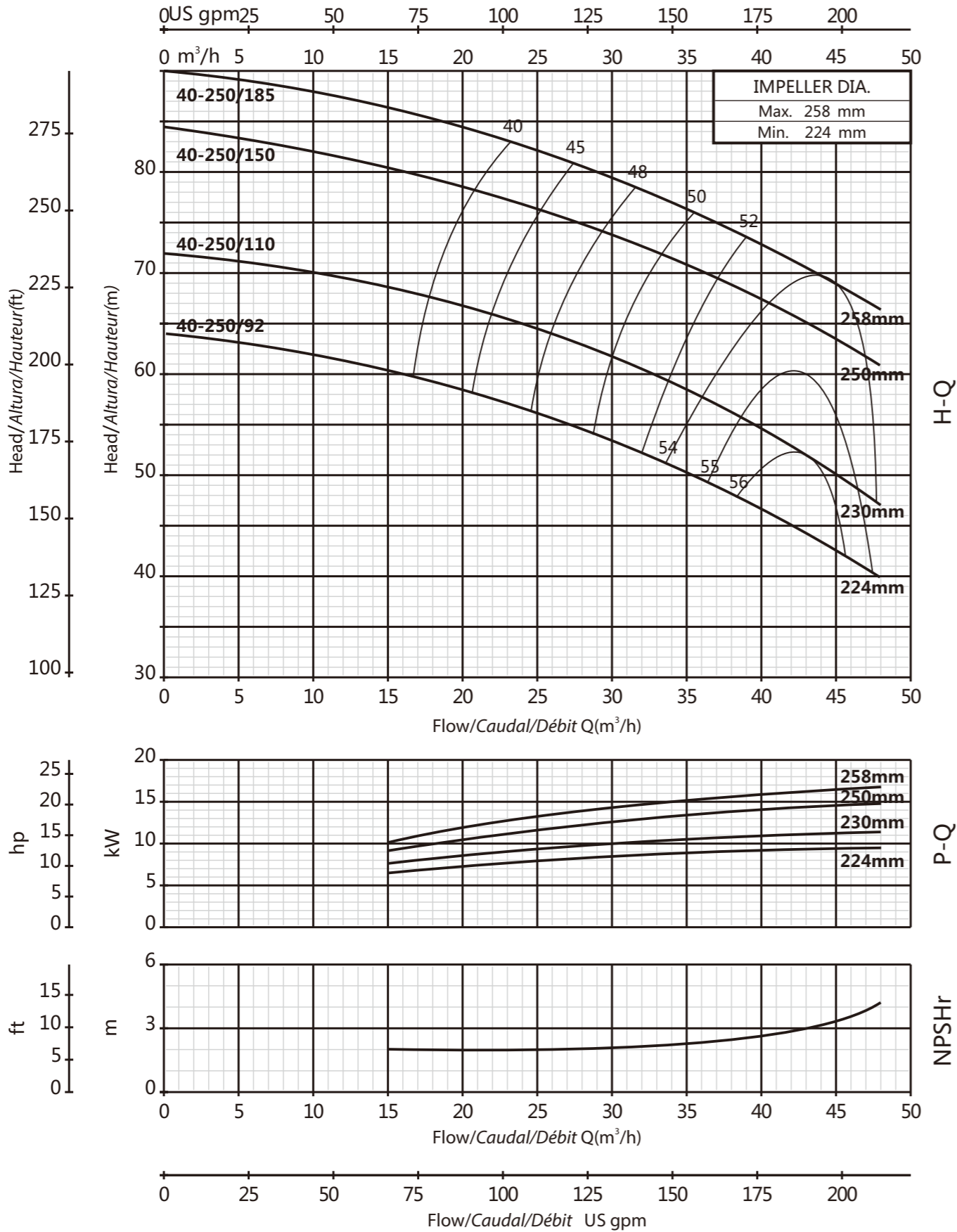

40-315

2900rpm

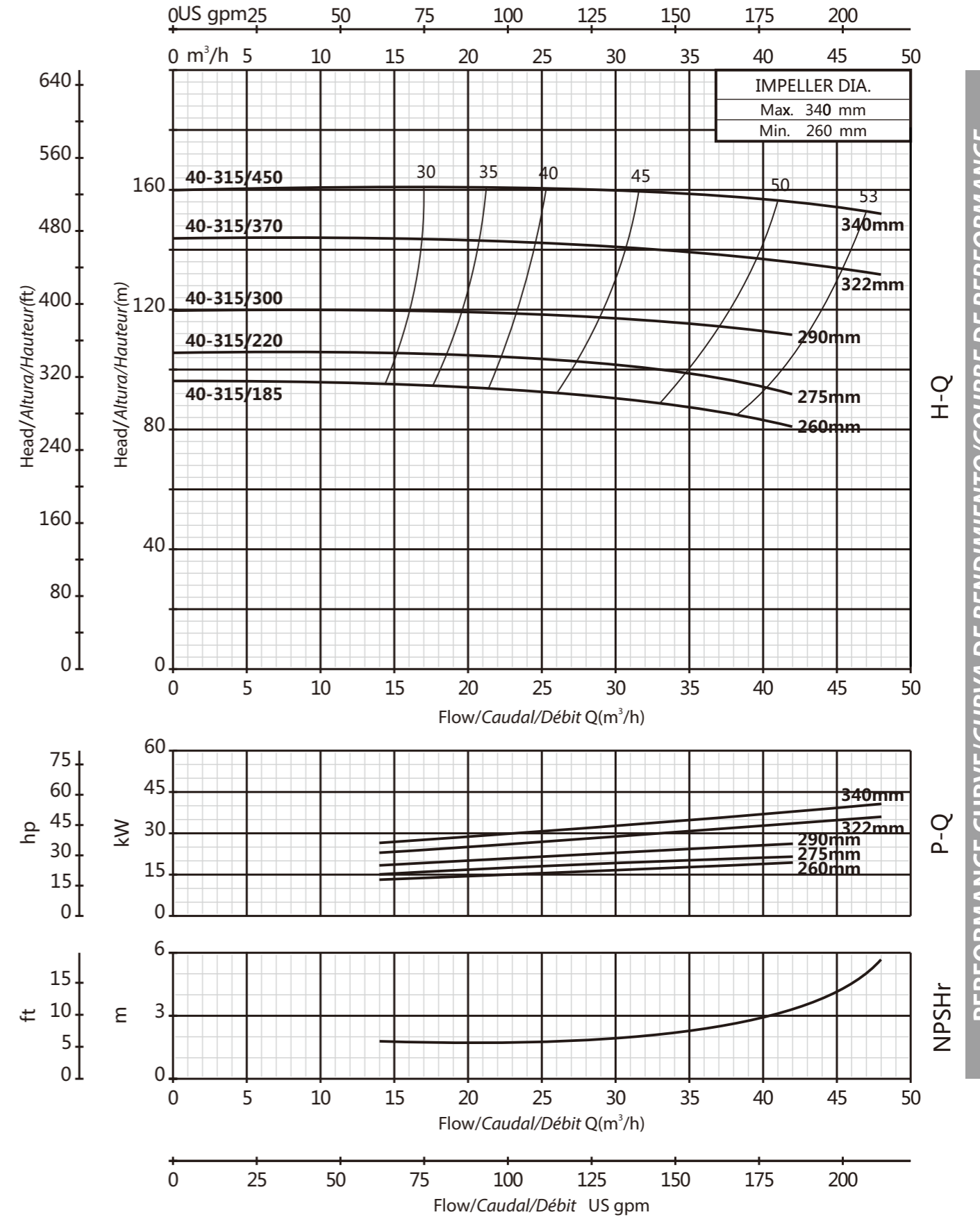

PERFORMANCE CURVE/CURVA DE RENDIMIENTO/COURBE DE PERFORMANCE

PERFORMANCE CURVE/CURVA DE RENDIMIENTO/COURBE DE PERFORMANCE

50-125

2900rpm

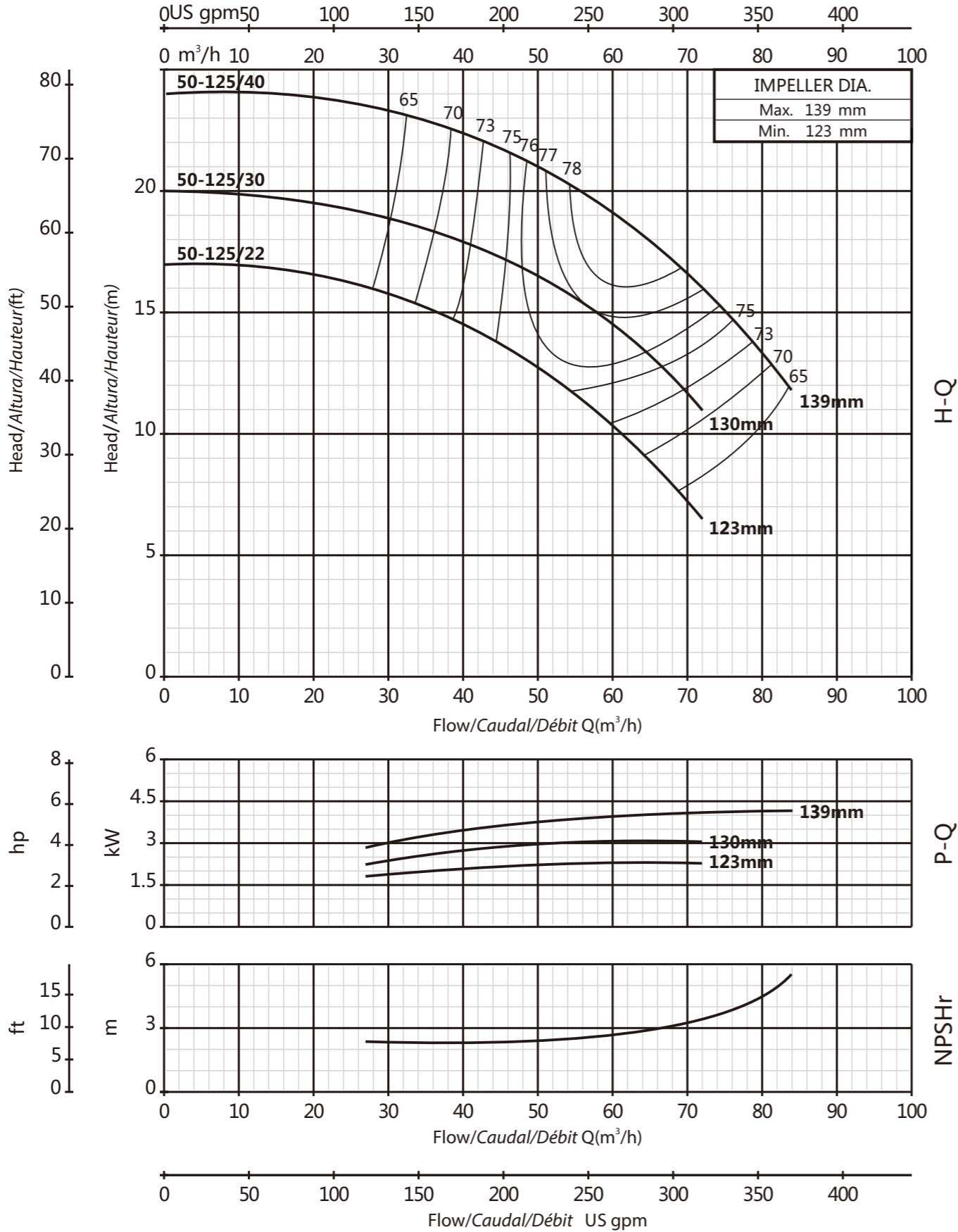

50-160

2900rpm

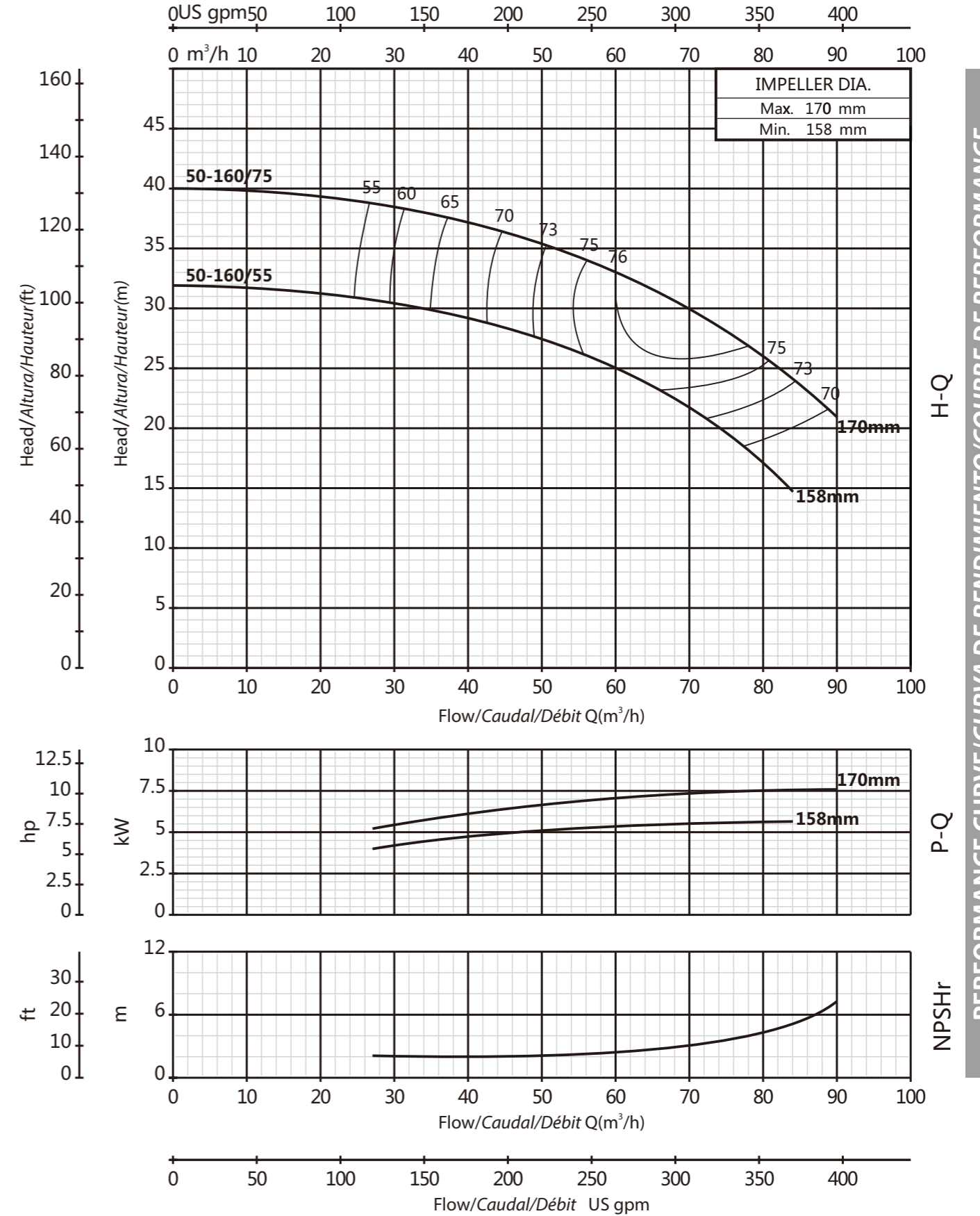

PERFORMANCE CURVE/CURVA DE RENDIMIENTO/COURBE DE PERFORMANCE

PERFORMANCE CURVE/CURVA DE RENDIMIENTO/COURBE DE PERFORMANCE

50-200

2900rpm

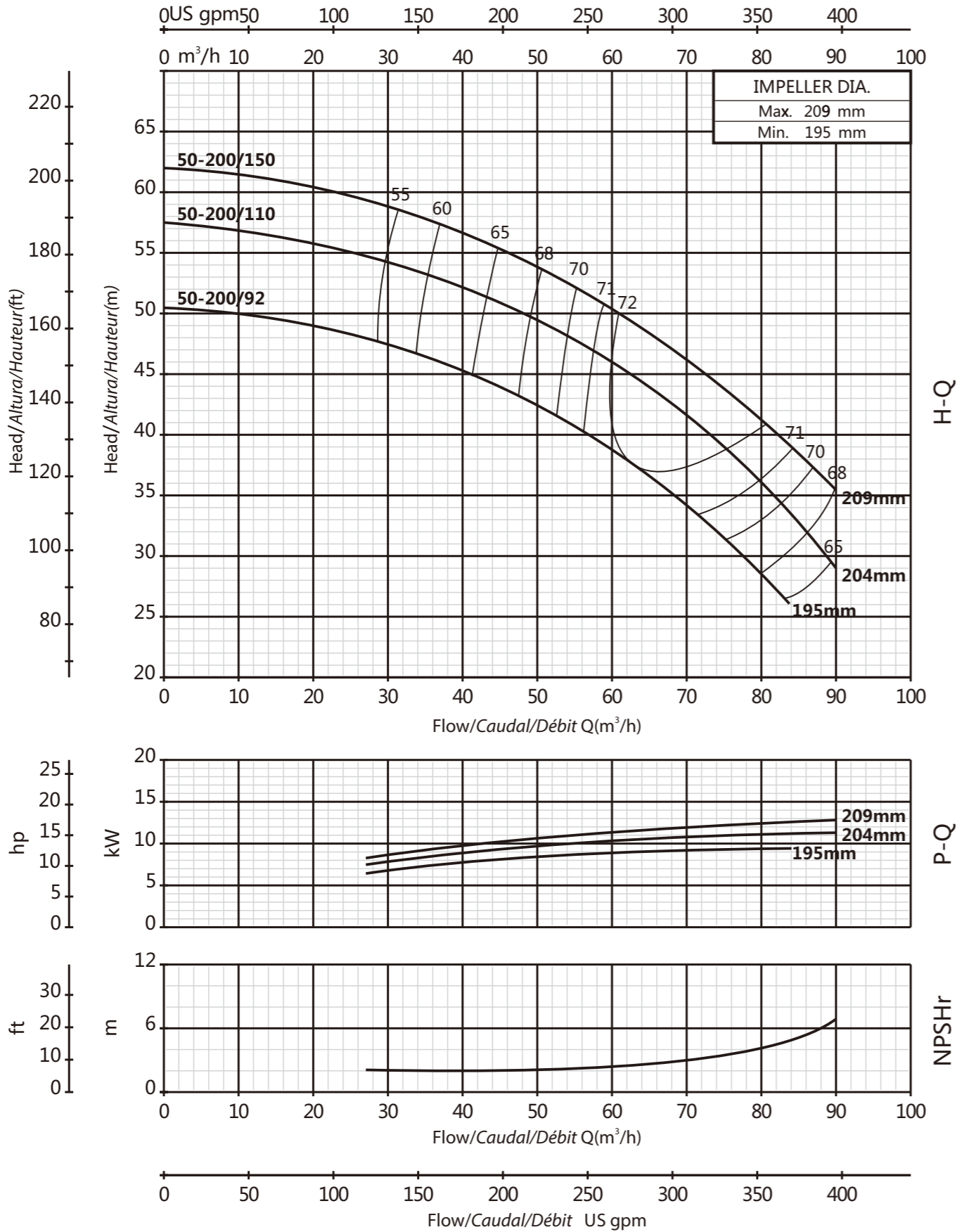

50-250

2900rpm

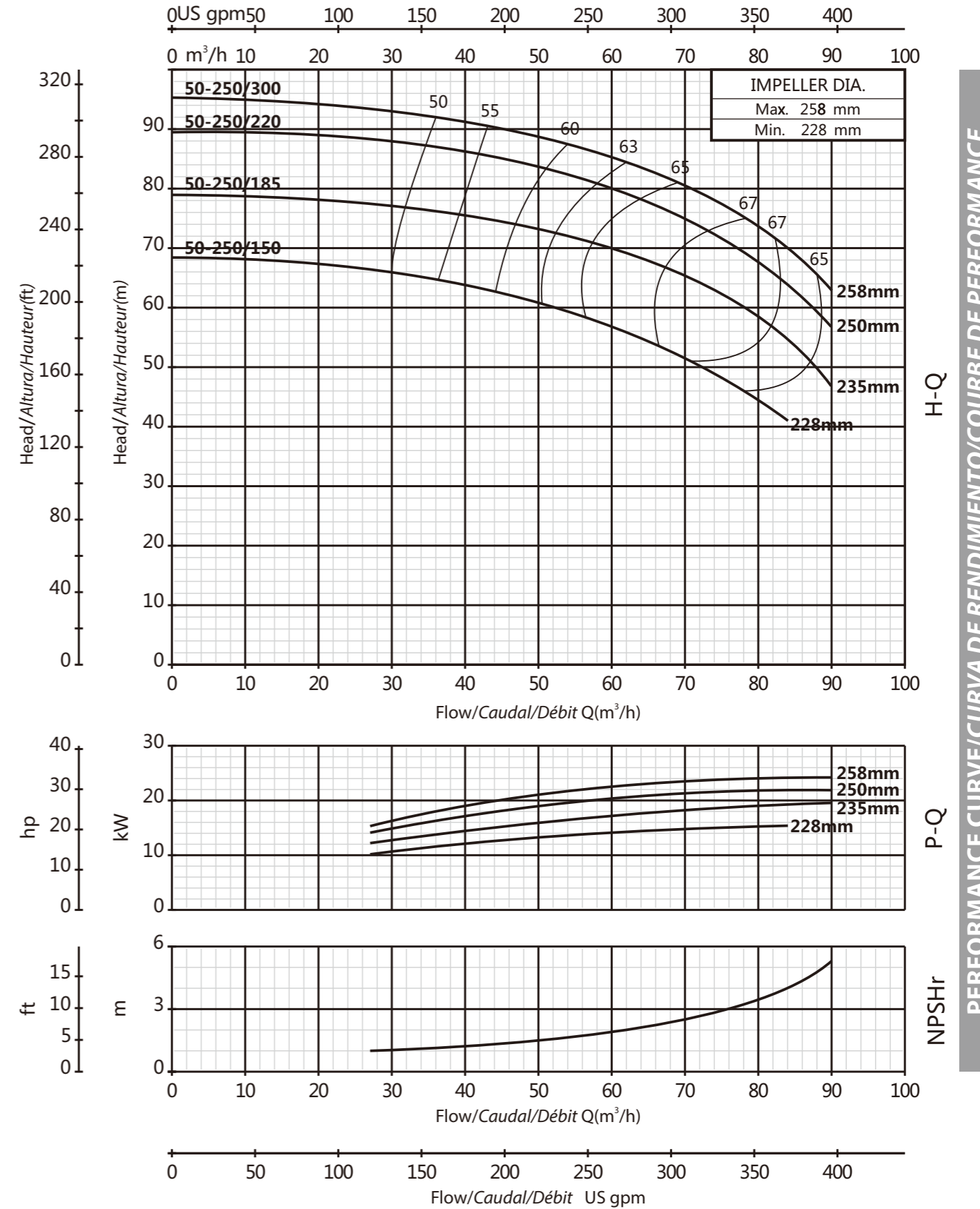

PERFORMANCE CURVE/CURVA DE RENDIMIENTO/COURBE DE PERFORMANCE

PERFORMANCE CURVE/CURVA DE RENDIMIENTO/COURBE DE PERFORMANCE

50-315

2900rpm

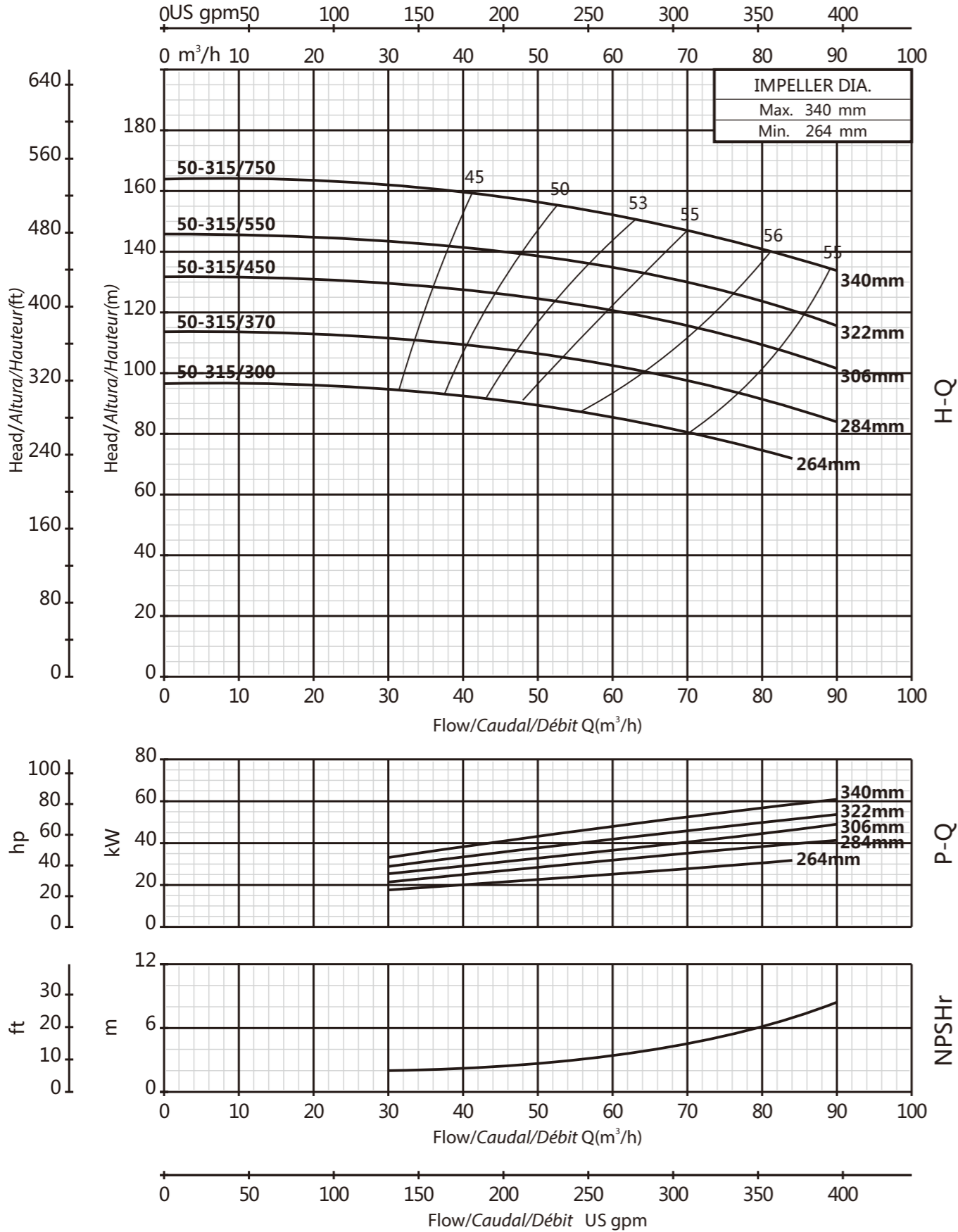

65-125

2900rpm

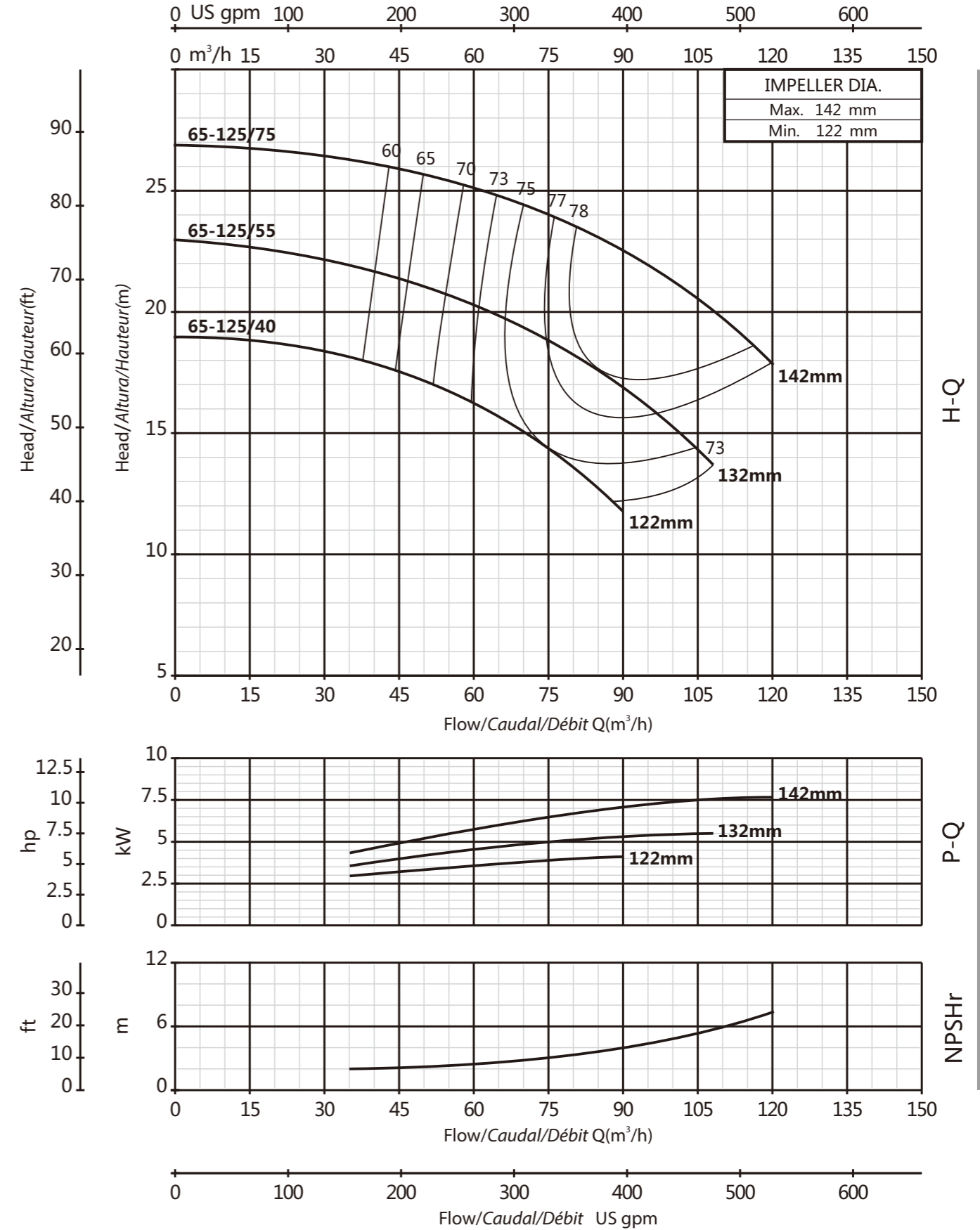

PERFORMANCE CURVE/CURVA DE RENDIMIENTO/COURBE DE PERFORMANCE

PERFORMANCE CURVE/CURVA DE RENDIMIENTO/COURBE DE PERFORMANCE

65-160

2900rpm

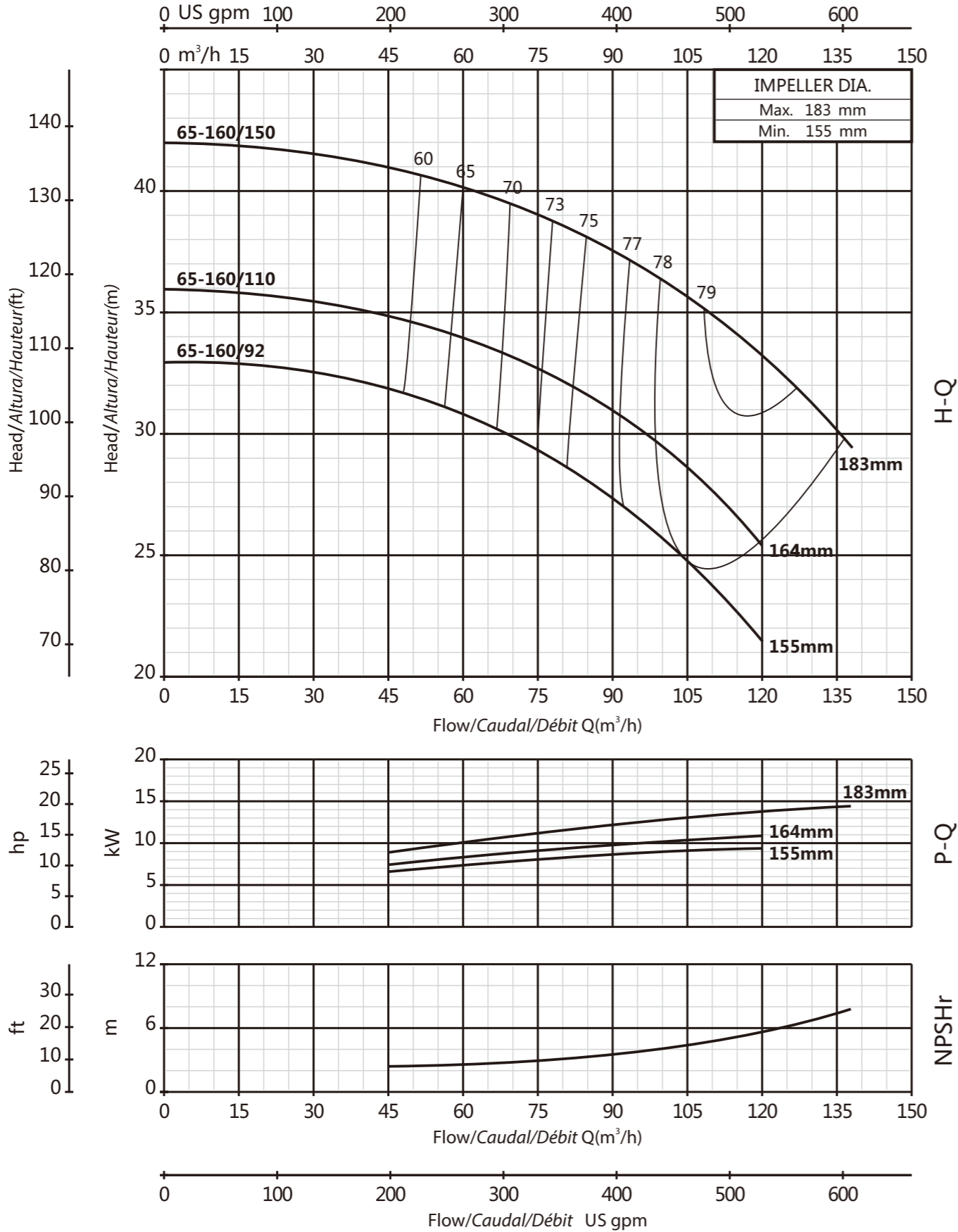

65-200

2900rpm

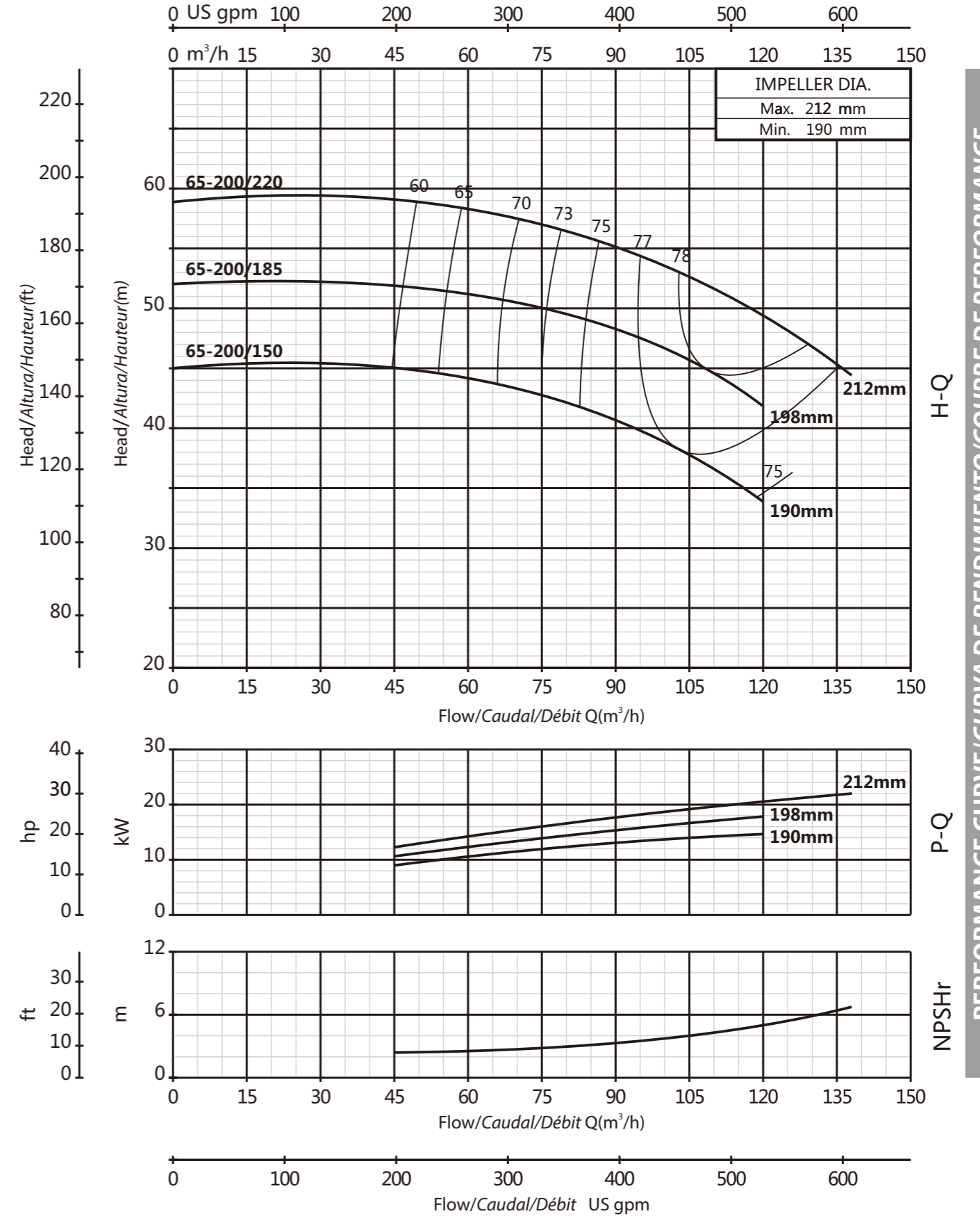

PERFORMANCE CURVE/CURVA DE RENDIMIENTO/COURBE DE PERFORMANCE

PERFORMANCE CURVE/CURVA DE RENDIMIENTO/COURBE DE PERFORMANCE

65-250

2900rpm

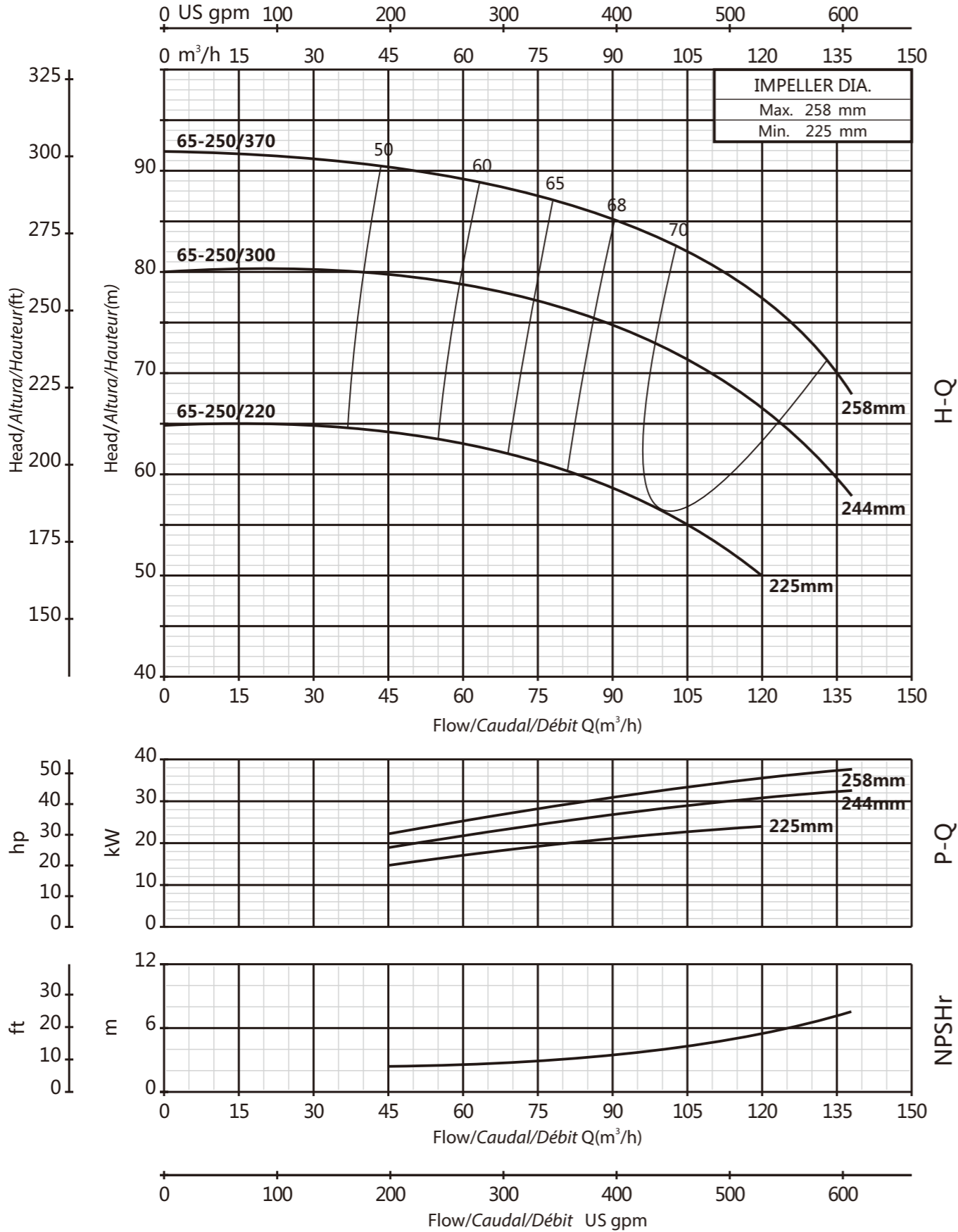

65-315

2900rpm

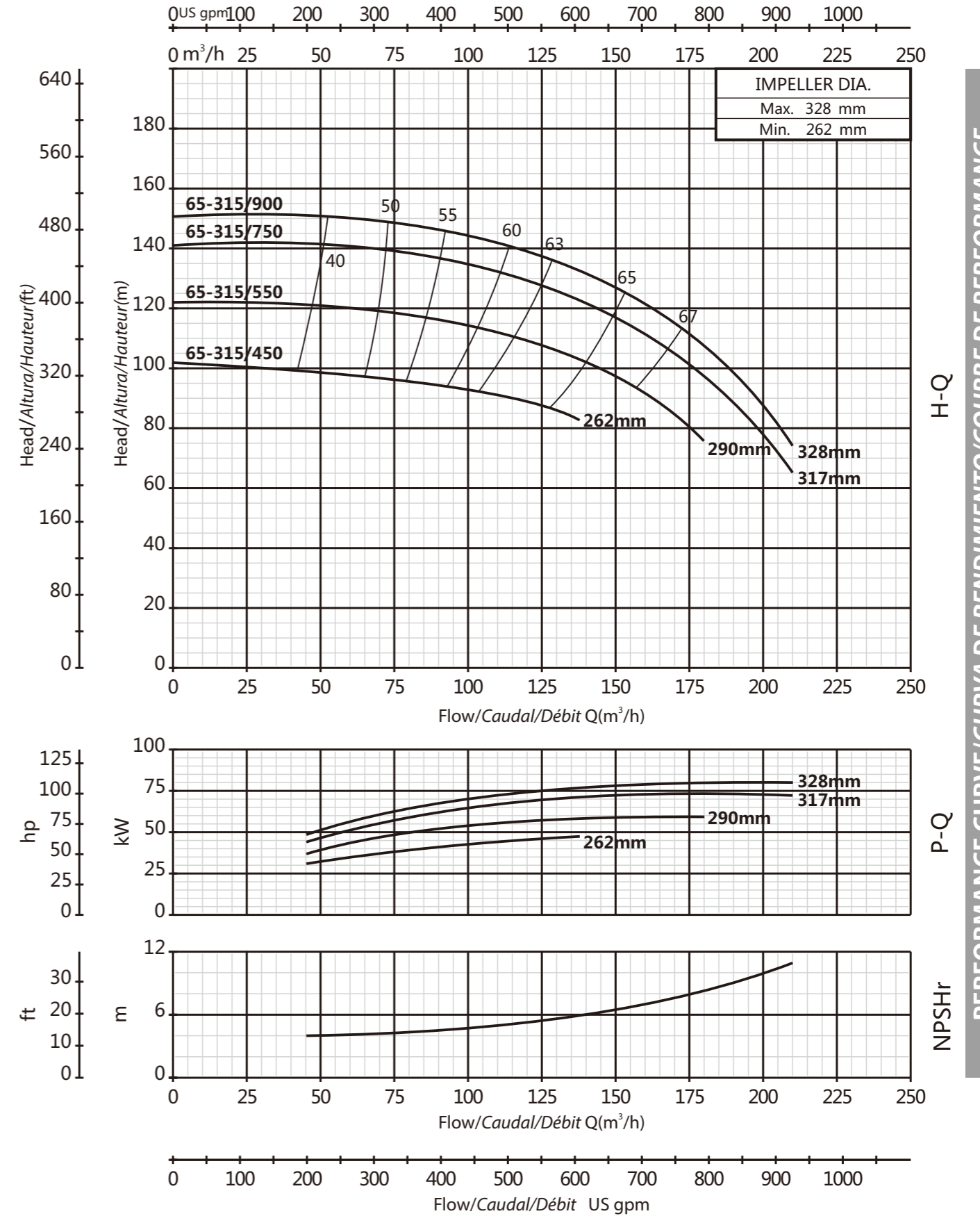

PERFORMANCE CURVE/CURVA DE RENDIMIENTO/COURBE DE PERFORMANCE

PERFORMANCE CURVE/CURVA DE RENDIMIENTO/COURBE DE PERFORMANCE

80-125

2900rpm

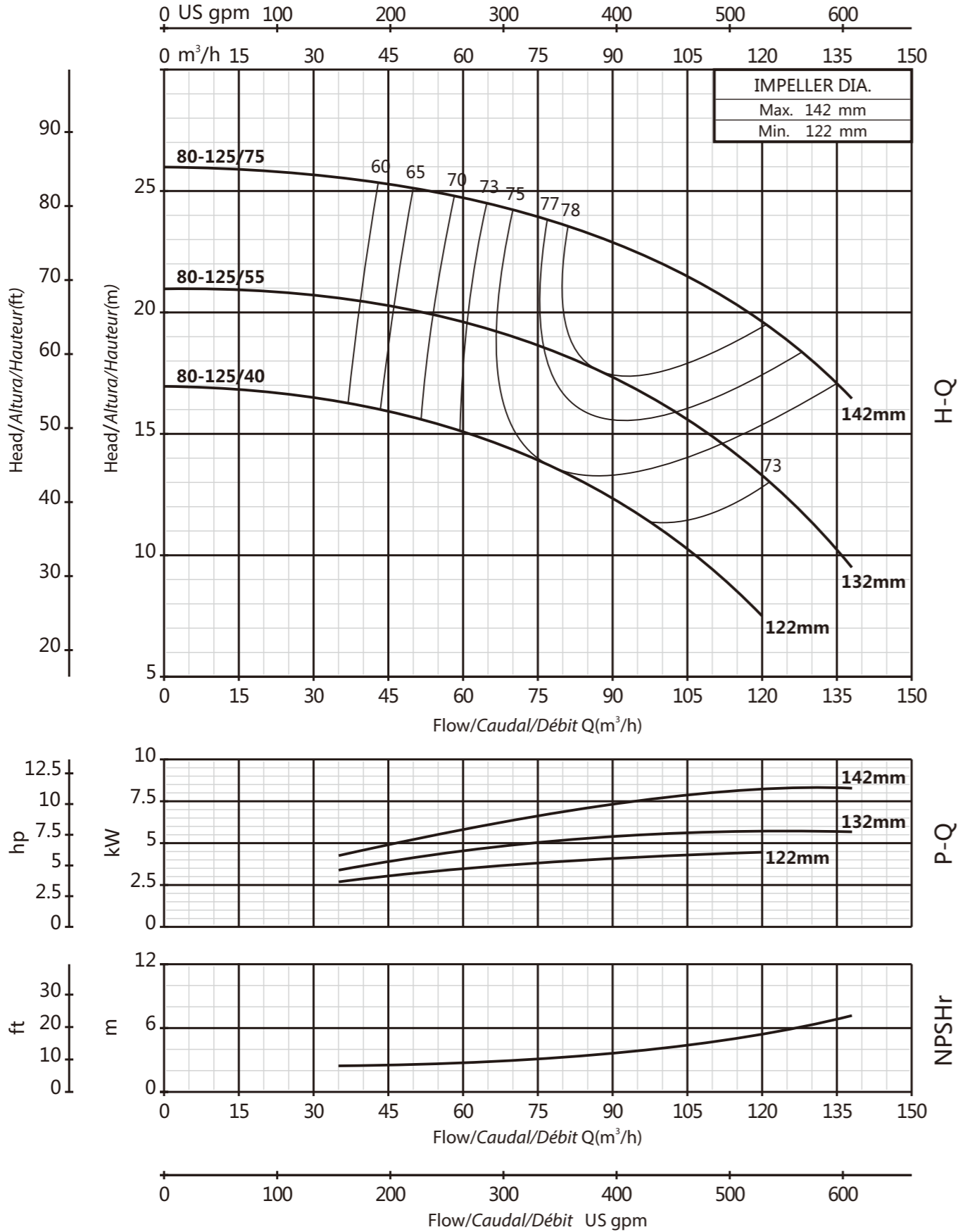

80-160

2900rpm

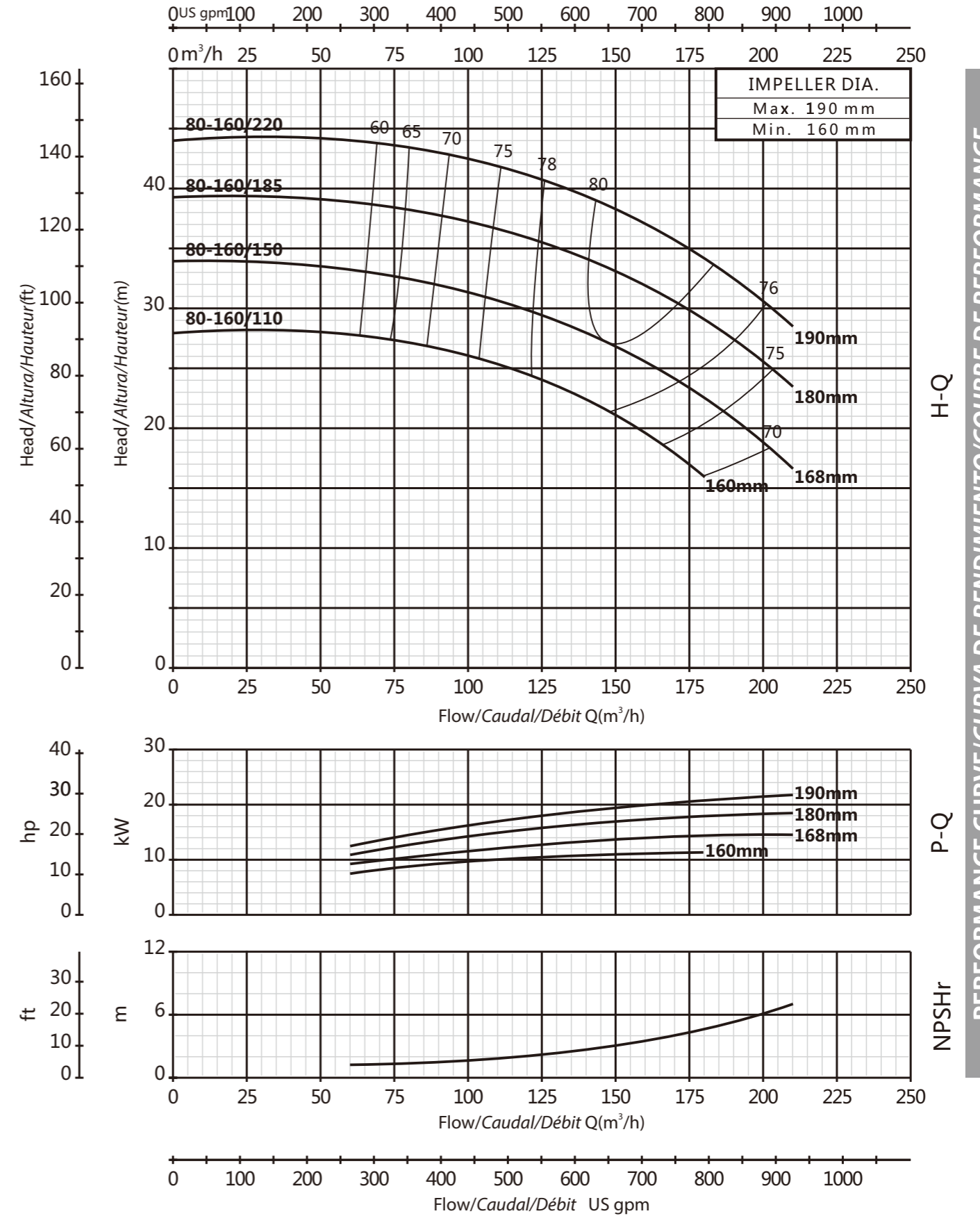

PERFORMANCE CURVE/CURVA DE RENDIMIENTO/COURBE DE PERFORMANCE

PERFORMANCE CURVE/CURVA DE RENDIMIENTO/COURBE DE PERFORMANCE

80-200

2900rpm

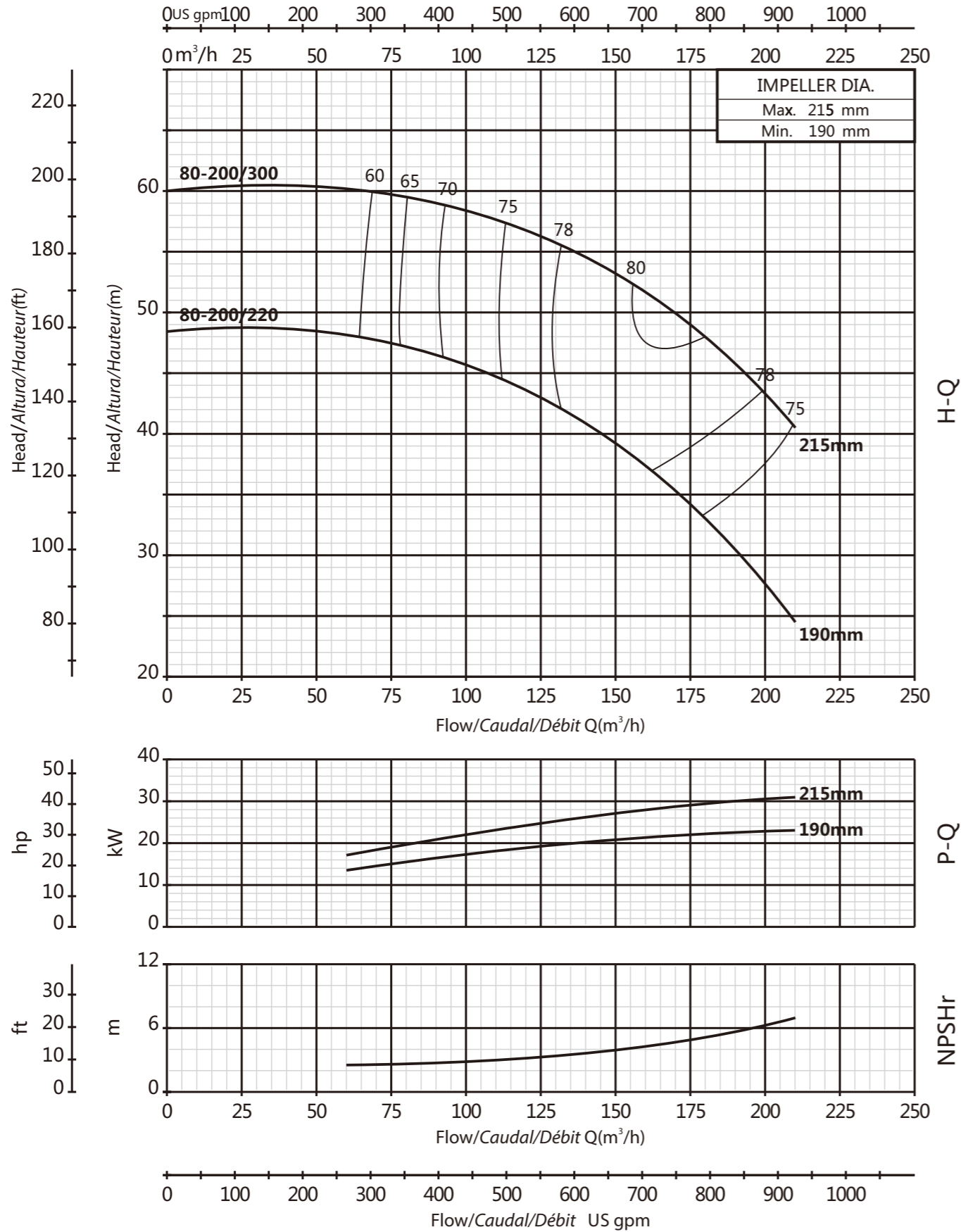

80-250

2900rpm

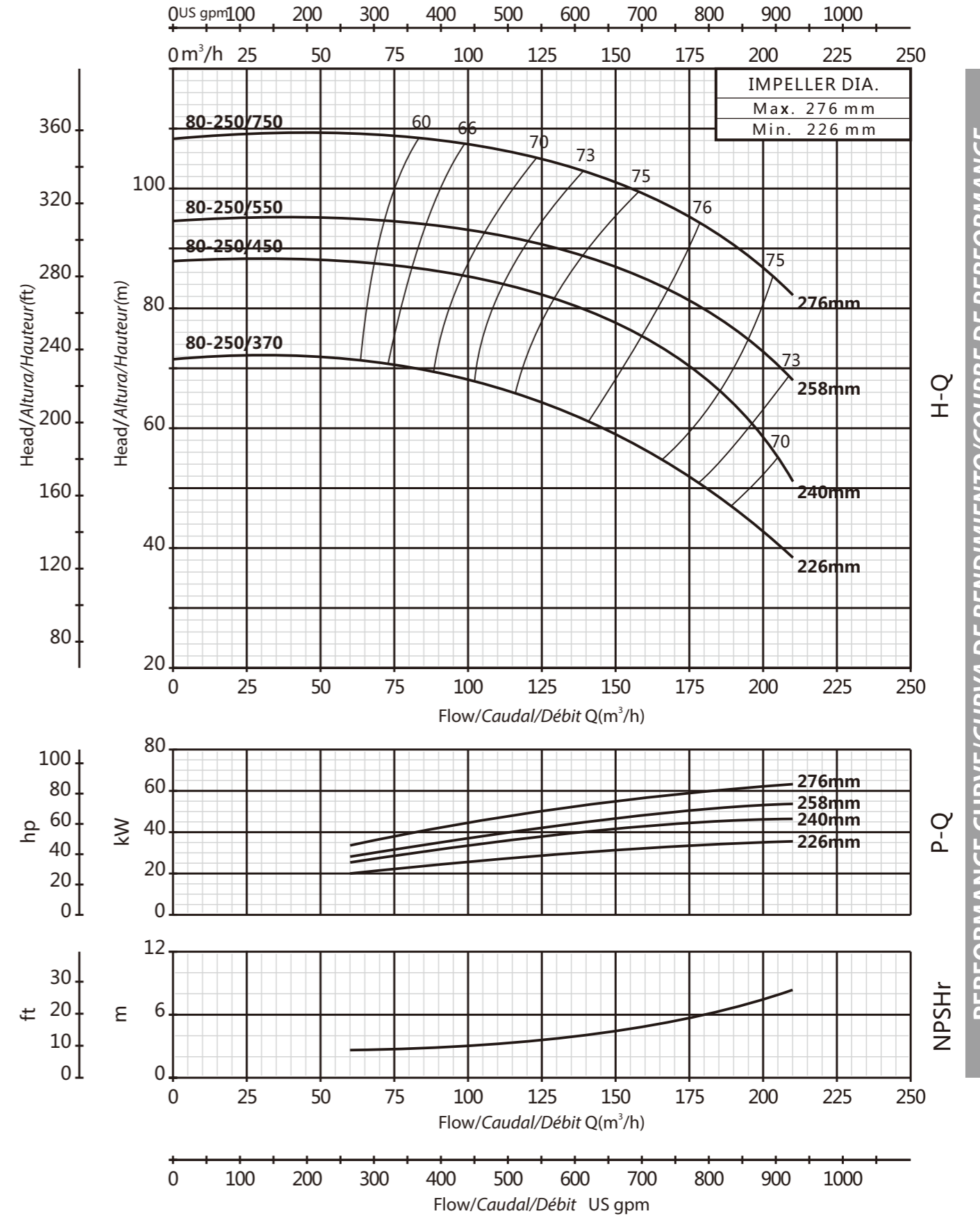

80-315

2900rpm

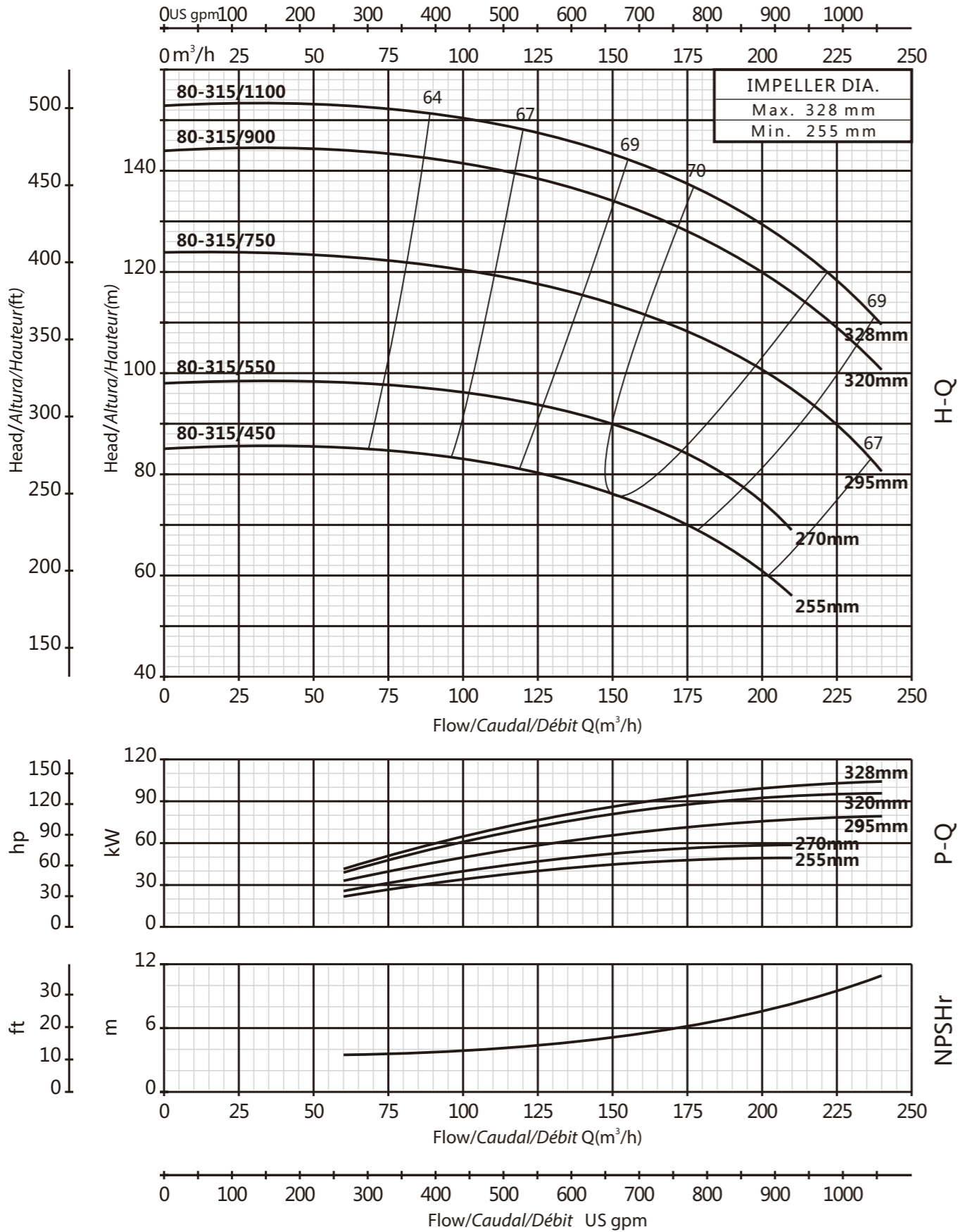

100-160

2900rpm

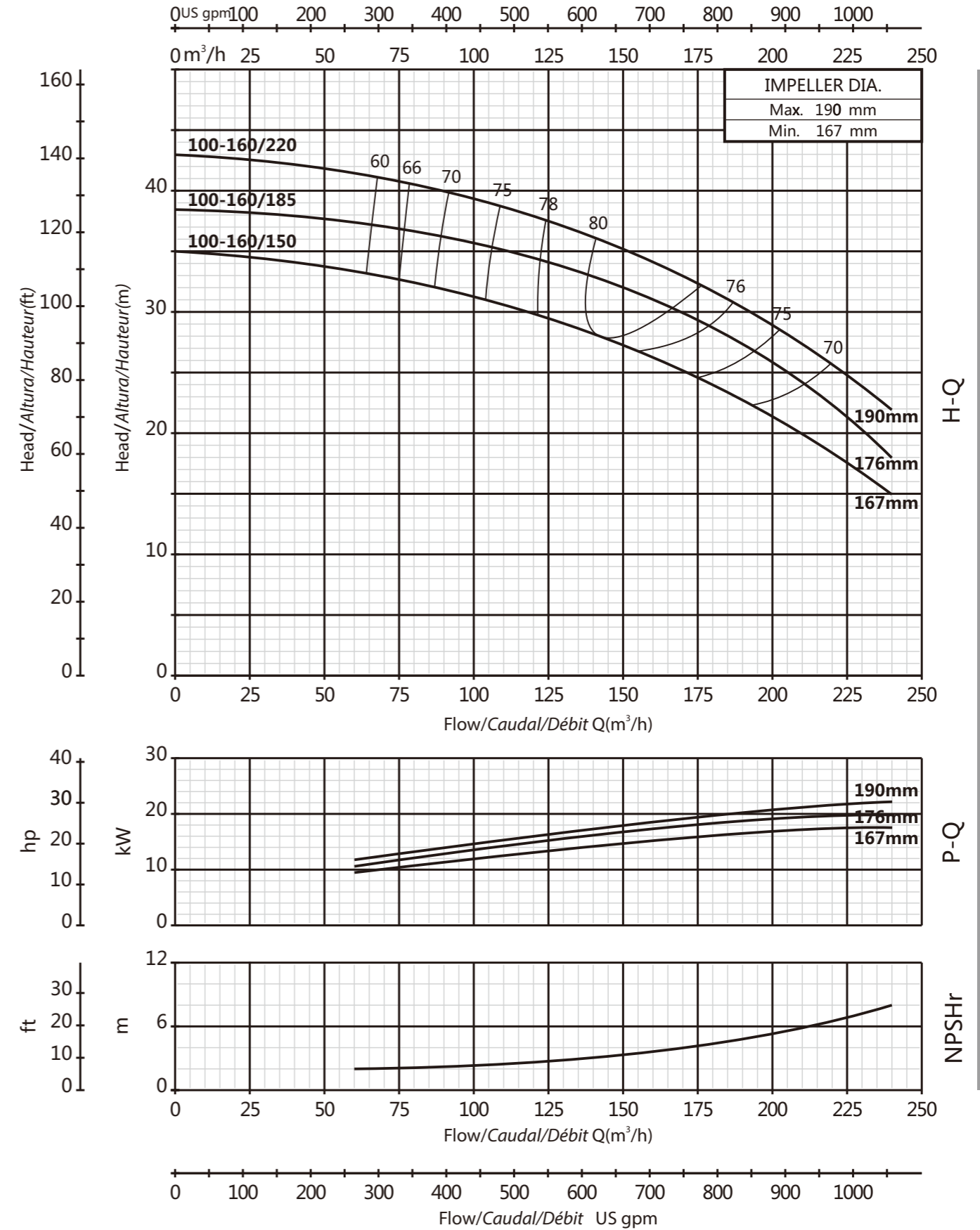

PERFORMANCE CURVE/CURVA DE RENDIMIENTO/COURBE DE PERFORMANCE

PERFORMANCE CURVE/CURVA DE RENDIMIENTO/COURBE DE PERFORMANCE

100-200

2900rpm

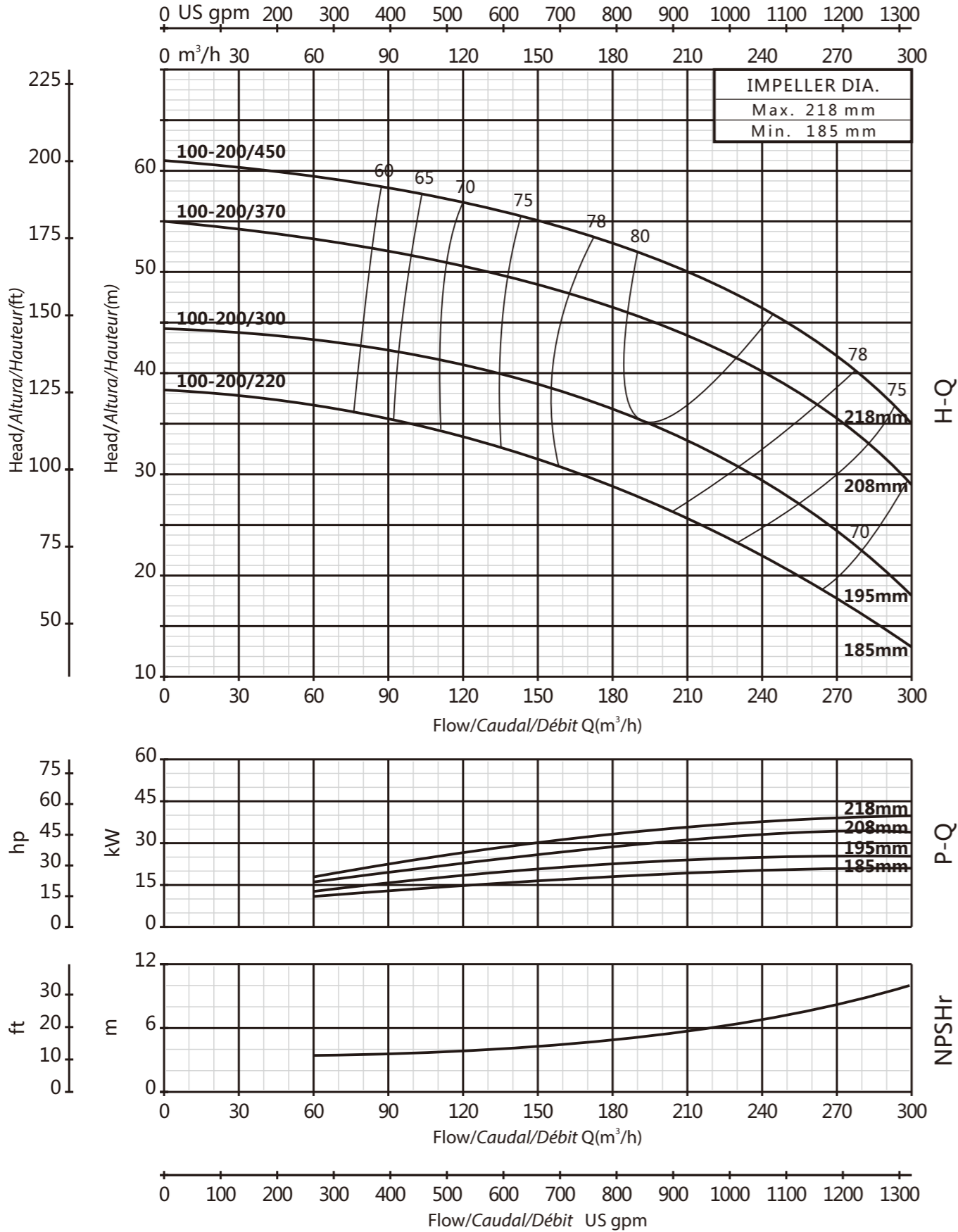

100-250

2900rpm

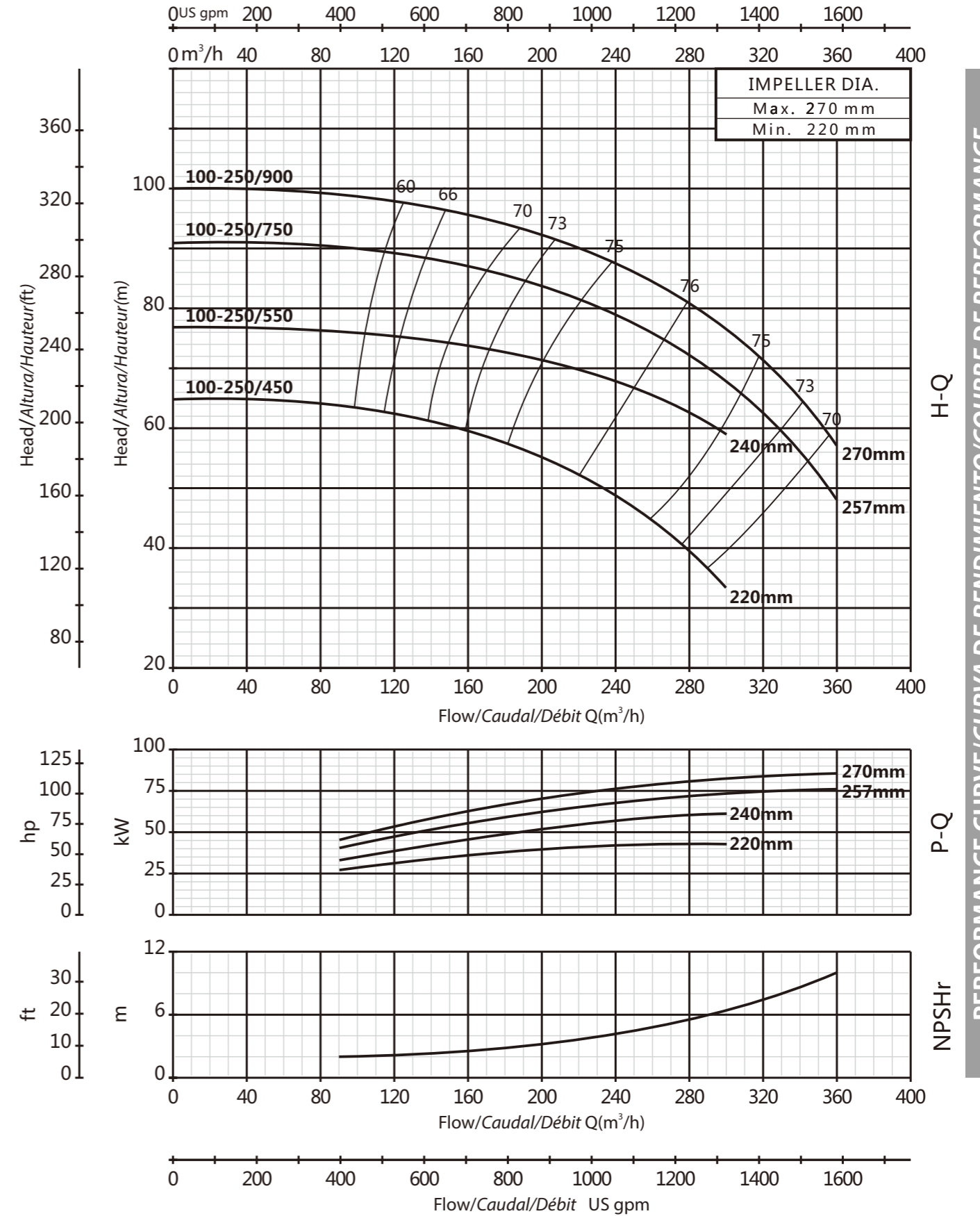

PERFORMANCE CURVE/CURVA DE RENDIMIENTO/COURBE DE PERFORMANCE

PERFORMANCE CURVE/CURVA DE RENDIMIENTO/COURBE DE PERFORMANCE

100-315

2900rpm

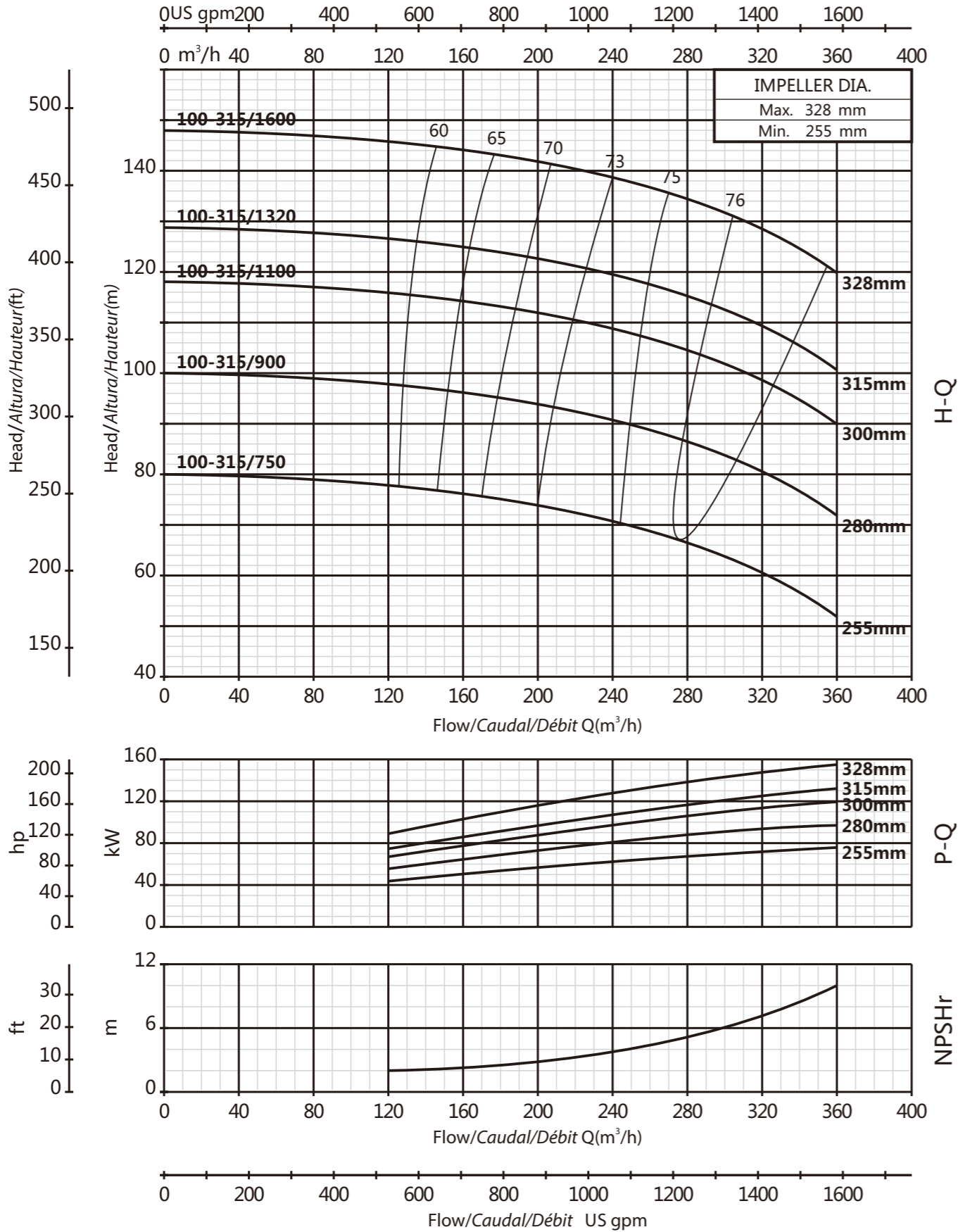

125-200

2900rpm

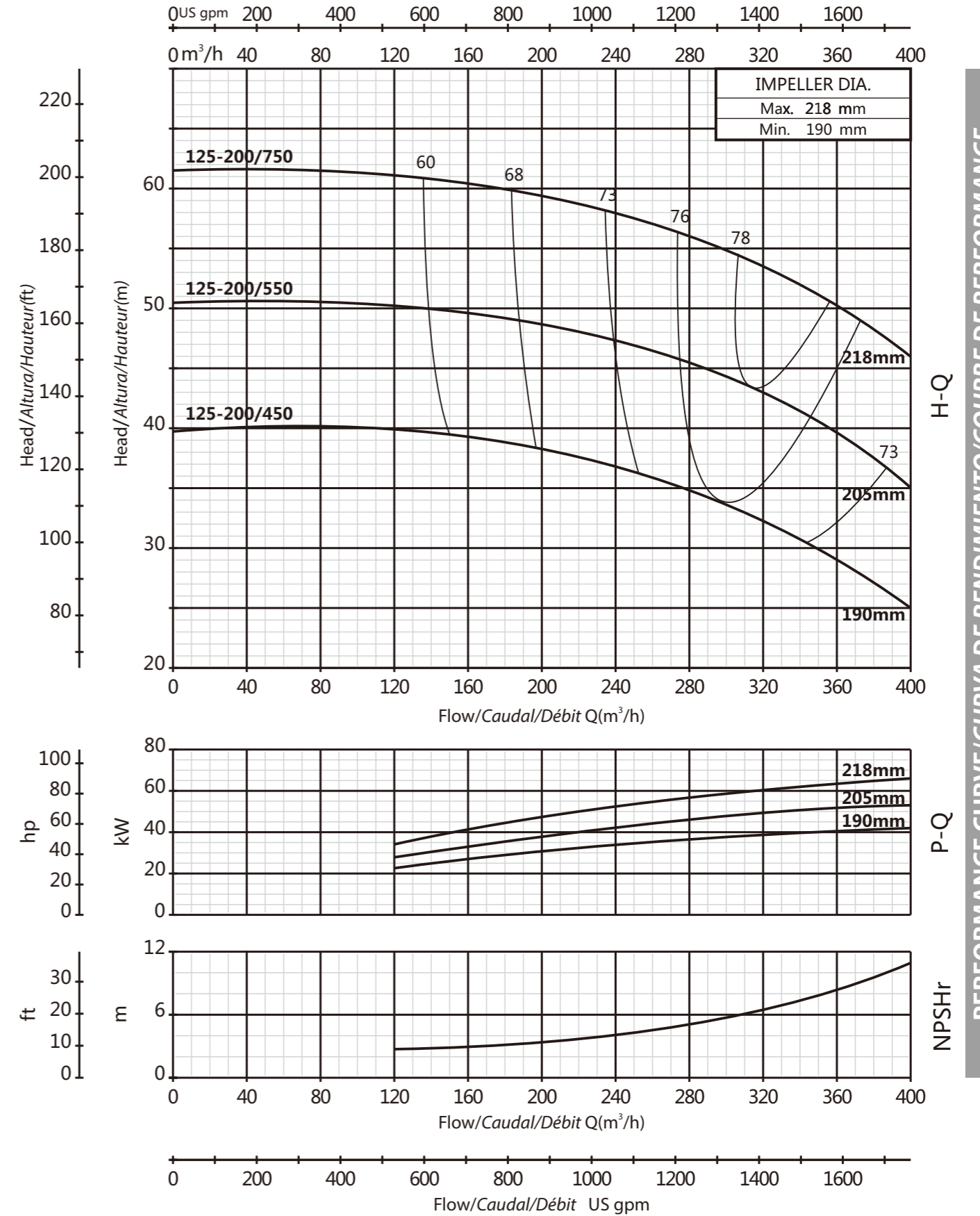

PERFORMANCE CURVE/CURVA DE RENDIMIENTO/COURBE DE PERFORMANCE

PERFORMANCE CURVE/CURVA DE RENDIMIENTO/COURBE DE PERFORMANCE

125-250

2900rpm

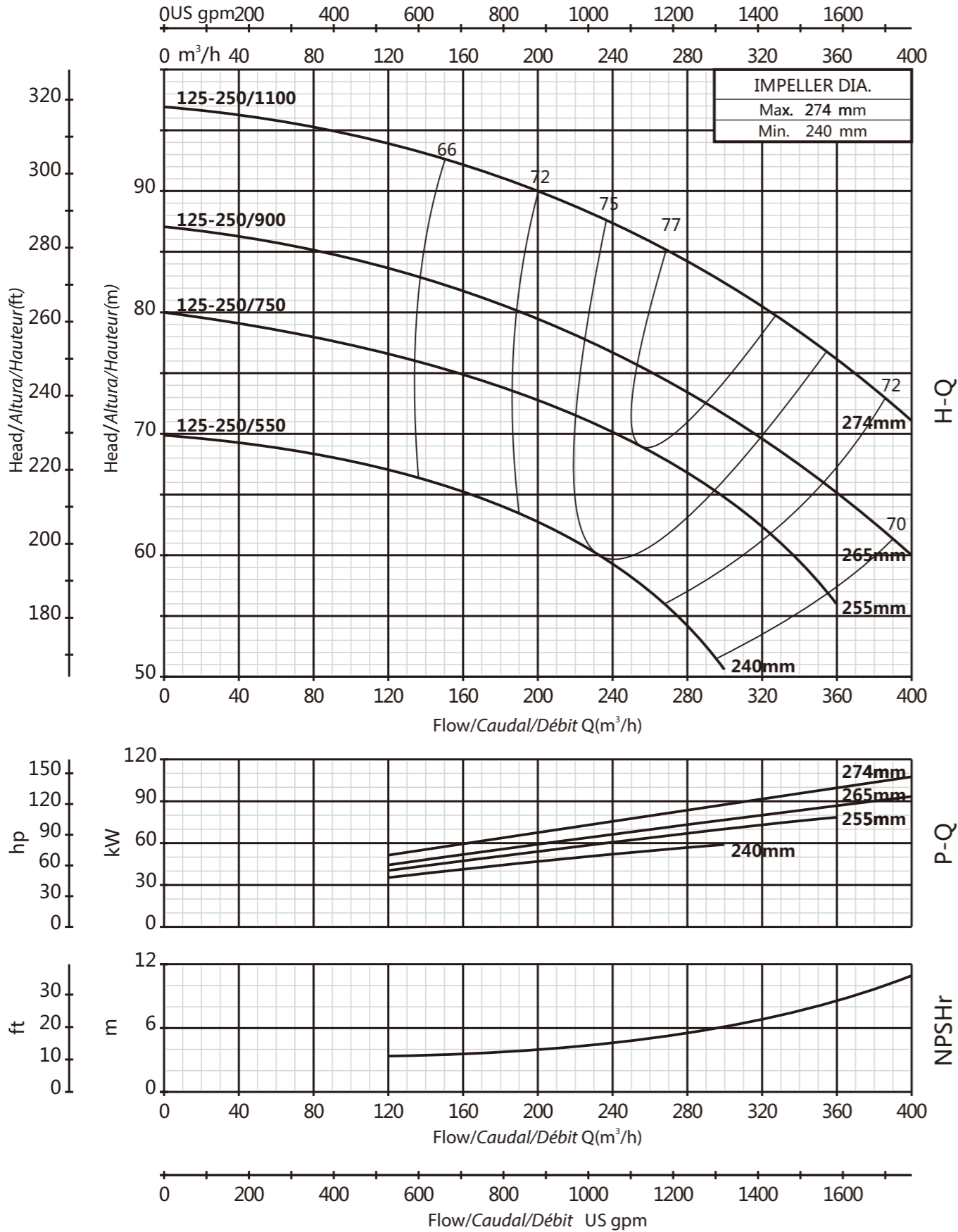

125-250H

2900rpm

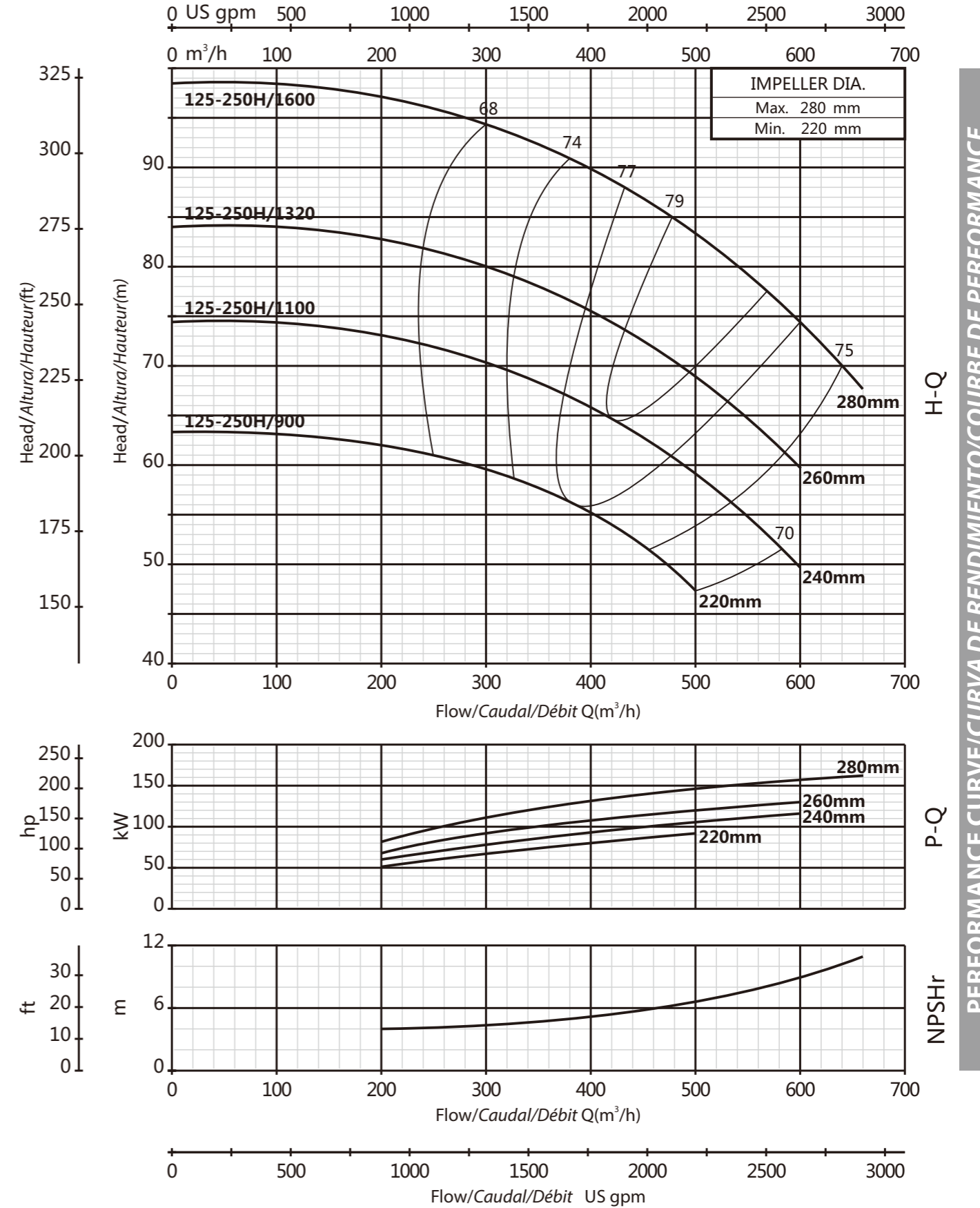

PERFORMANCE CURVE/CURVA DE RENDIMIENTO/COURBE DE PERFORMANCE

PERFORMANCE CURVE/CURVA DE RENDIMIENTO/COURBE DE PERFORMANCE

125-315

2900rpm

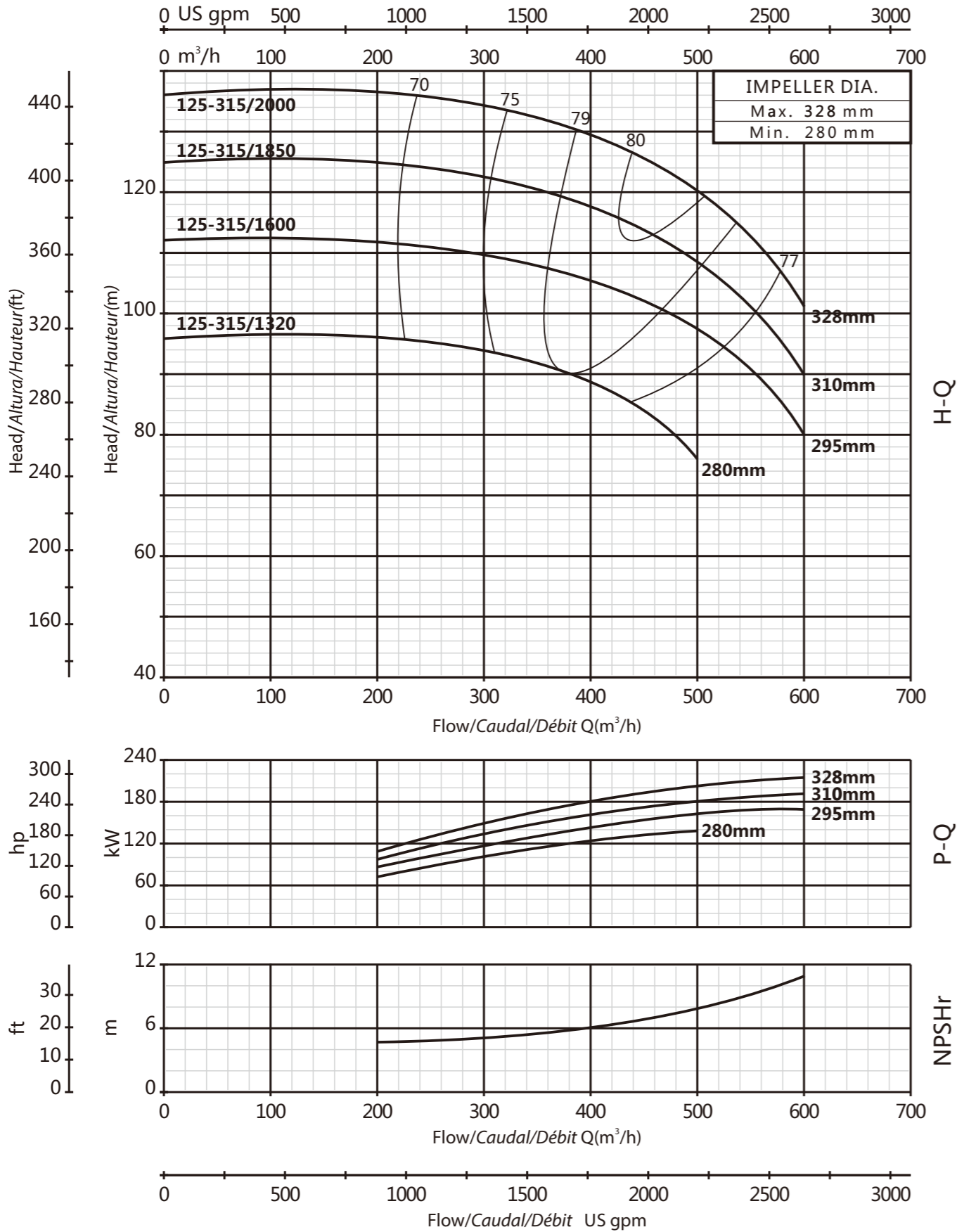

PERFORMANCE CURVE/CURVA DE RENDIMIENTO/COURBE DE PERFORMANCE

150-200

2900rpm

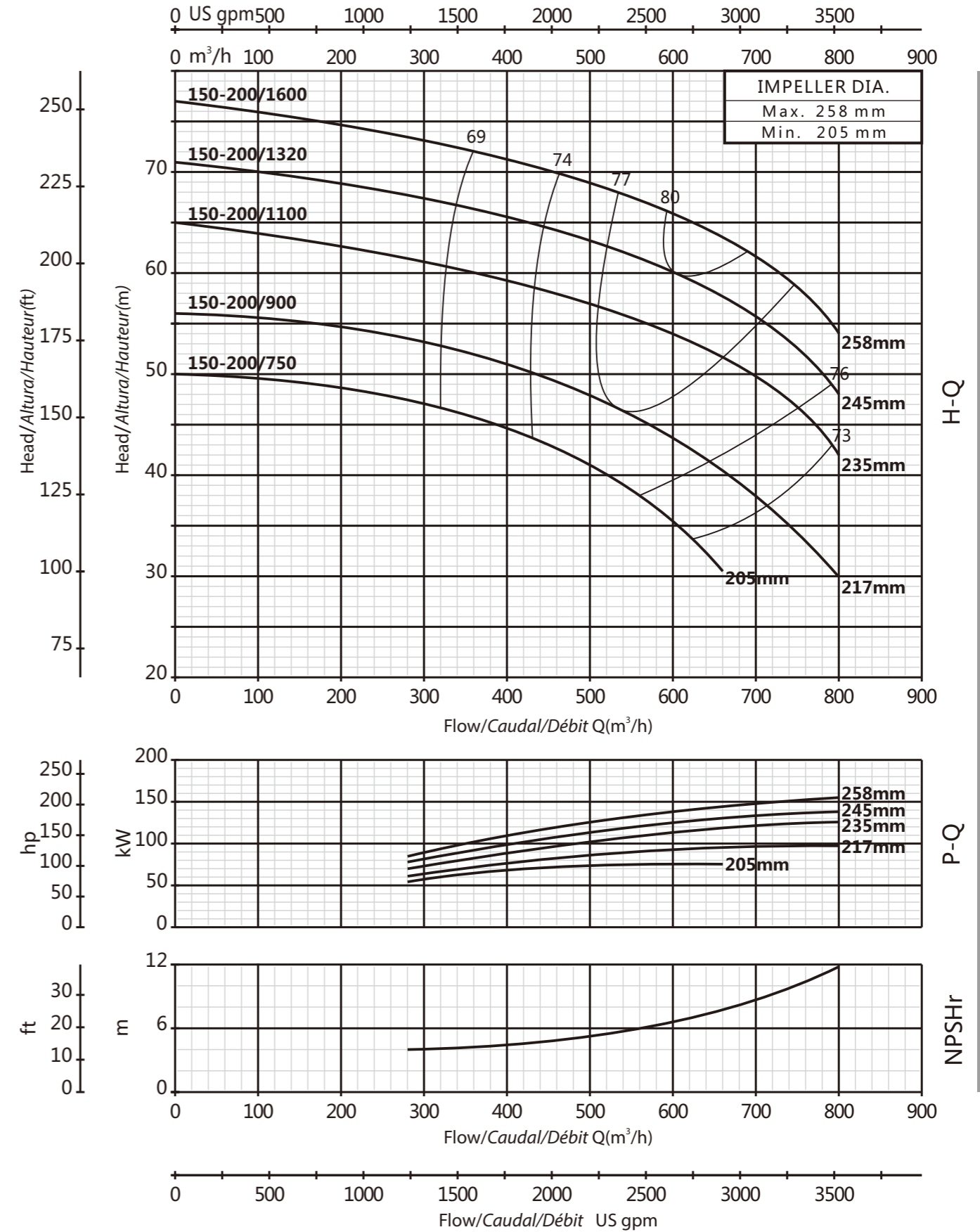

PERFORMANCE CURVE/CURVA DE RENDIMIENTO/COURBE DE PERFORMANCE

150-250

2900rpm

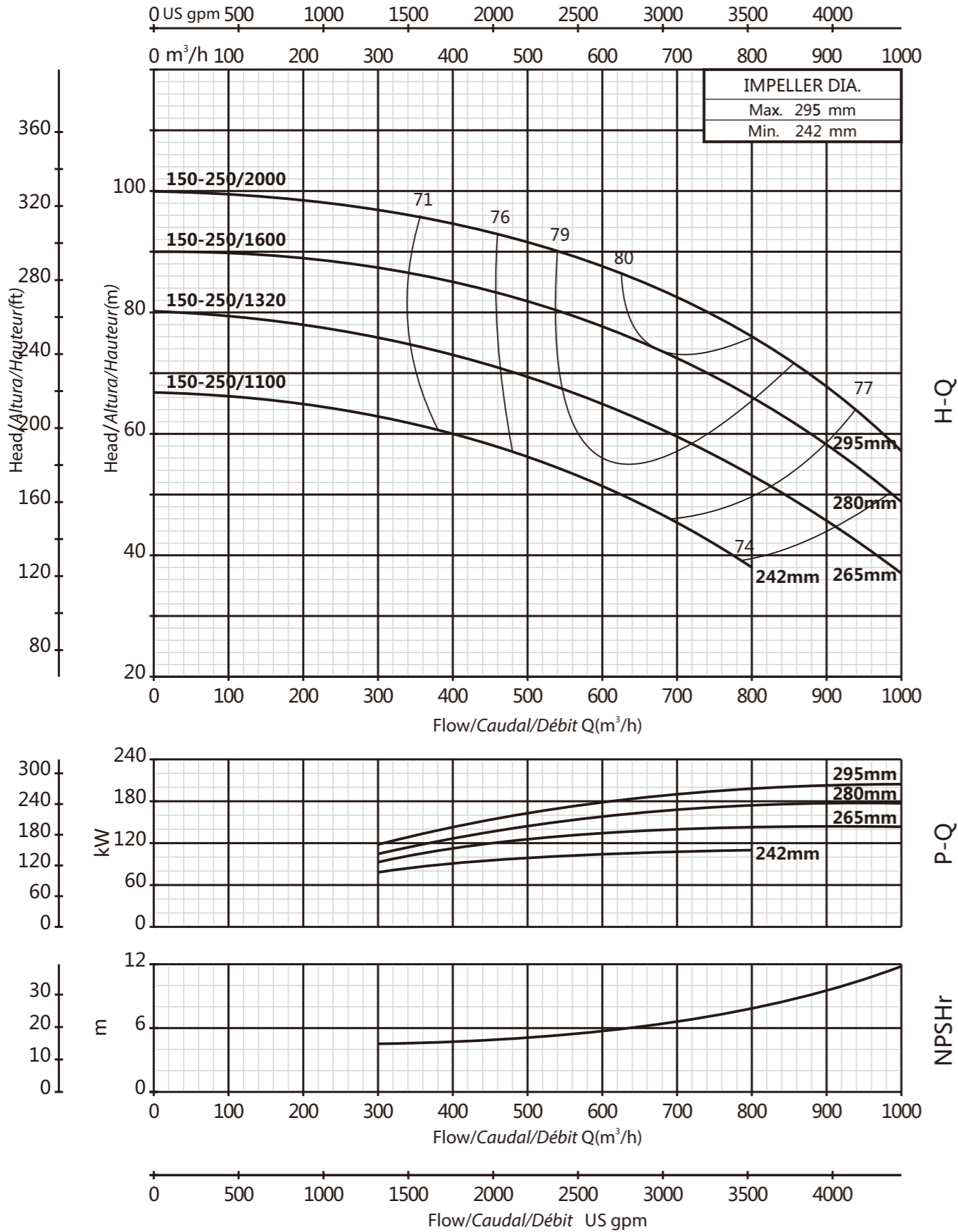

PERFORMANCE CURVE/CURVA DE RENDIMIENTO/COURBE DE PERFORMANCE

150-315

2900rpm

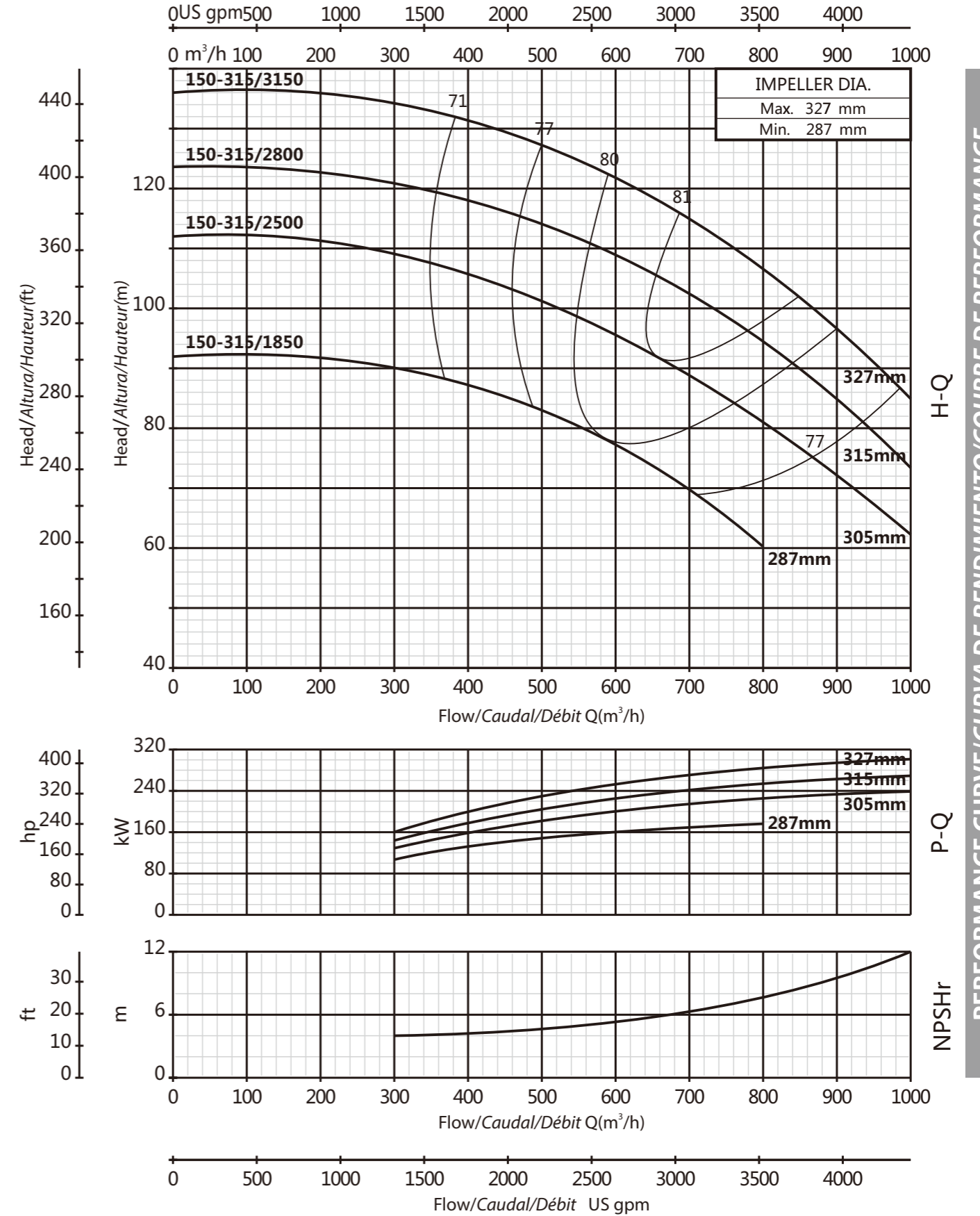

PERFORMANCE CURVE/CURVA DE RENDIMIENTO/COURBE DE PERFORMANCE

65-160

1450rpm

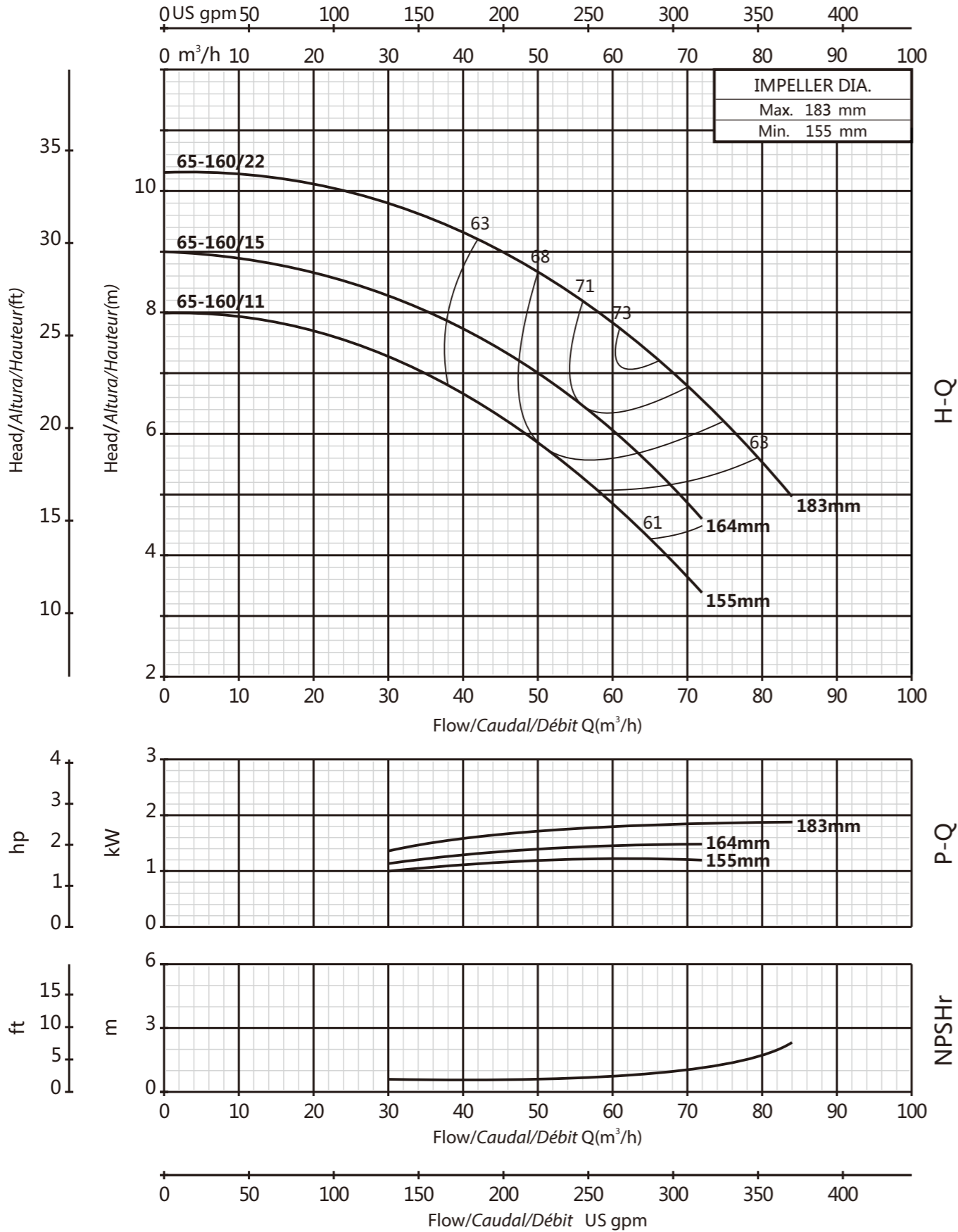

PERFORMANCE CURVE/CURVA DE RENDIMIENTO/COURBE DE PERFORMANCE

65-200

1450rpm

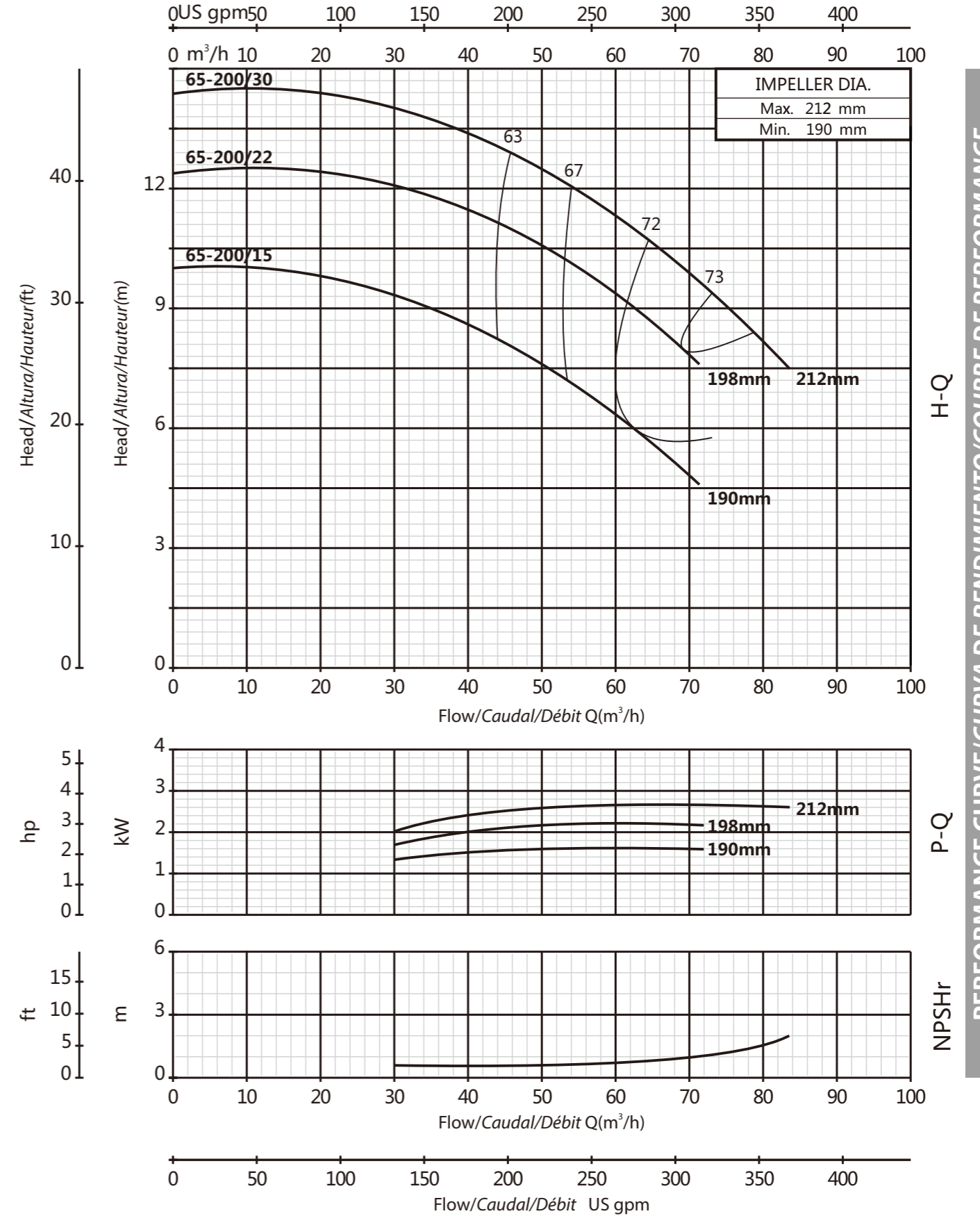

PERFORMANCE CURVE/CURVA DE RENDIMIENTO/COURBE DE PERFORMANCE

65-250

1450rpm

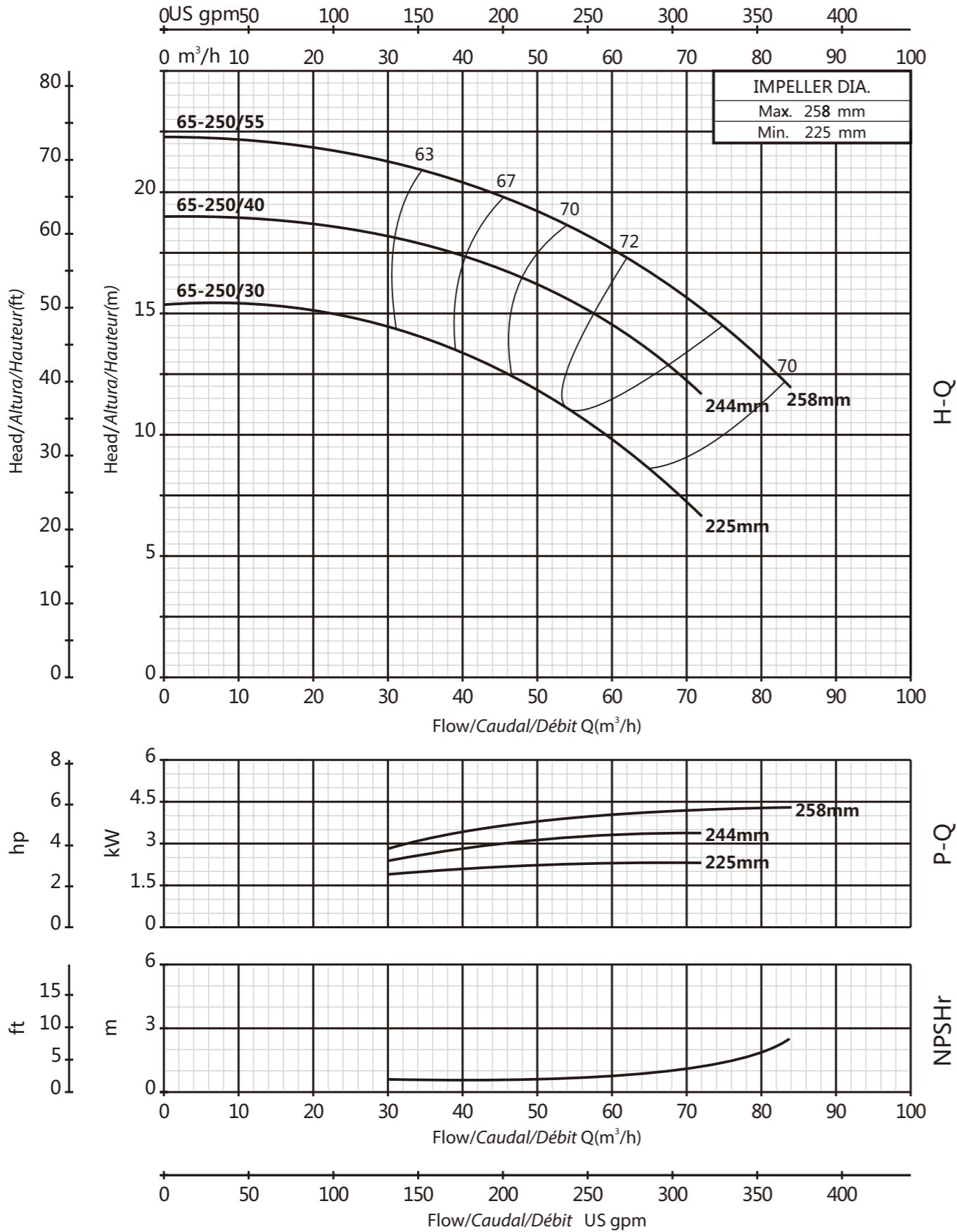

65-315

1450rpm

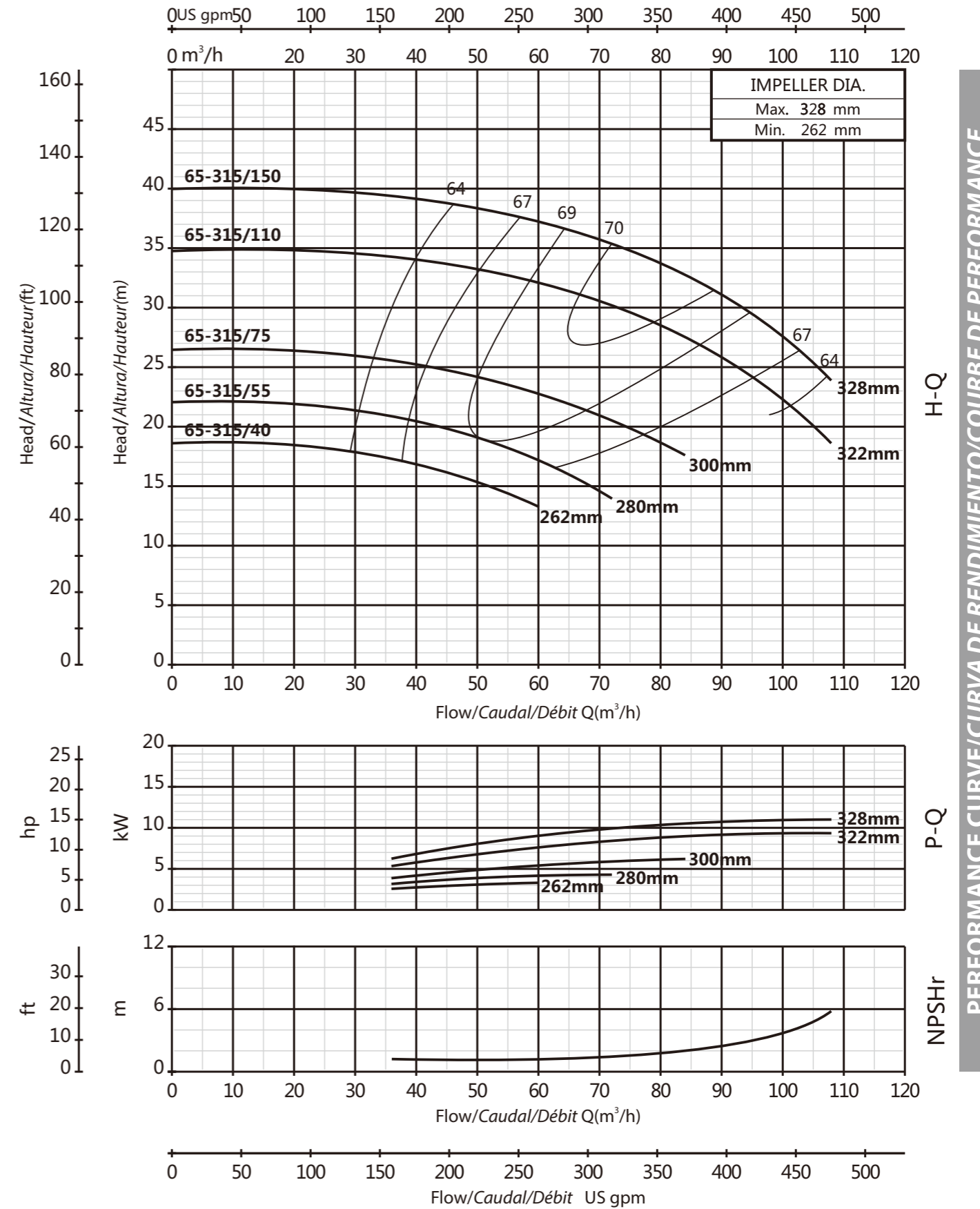

PERFORMANCE CURVE/CURVA DE RENDIMIENTO/COURBE DE PERFORMANCE

PERFORMANCE CURVE/CURVA DE RENDIMIENTO/COURBE DE PERFORMANCE

80-160

1450rpm

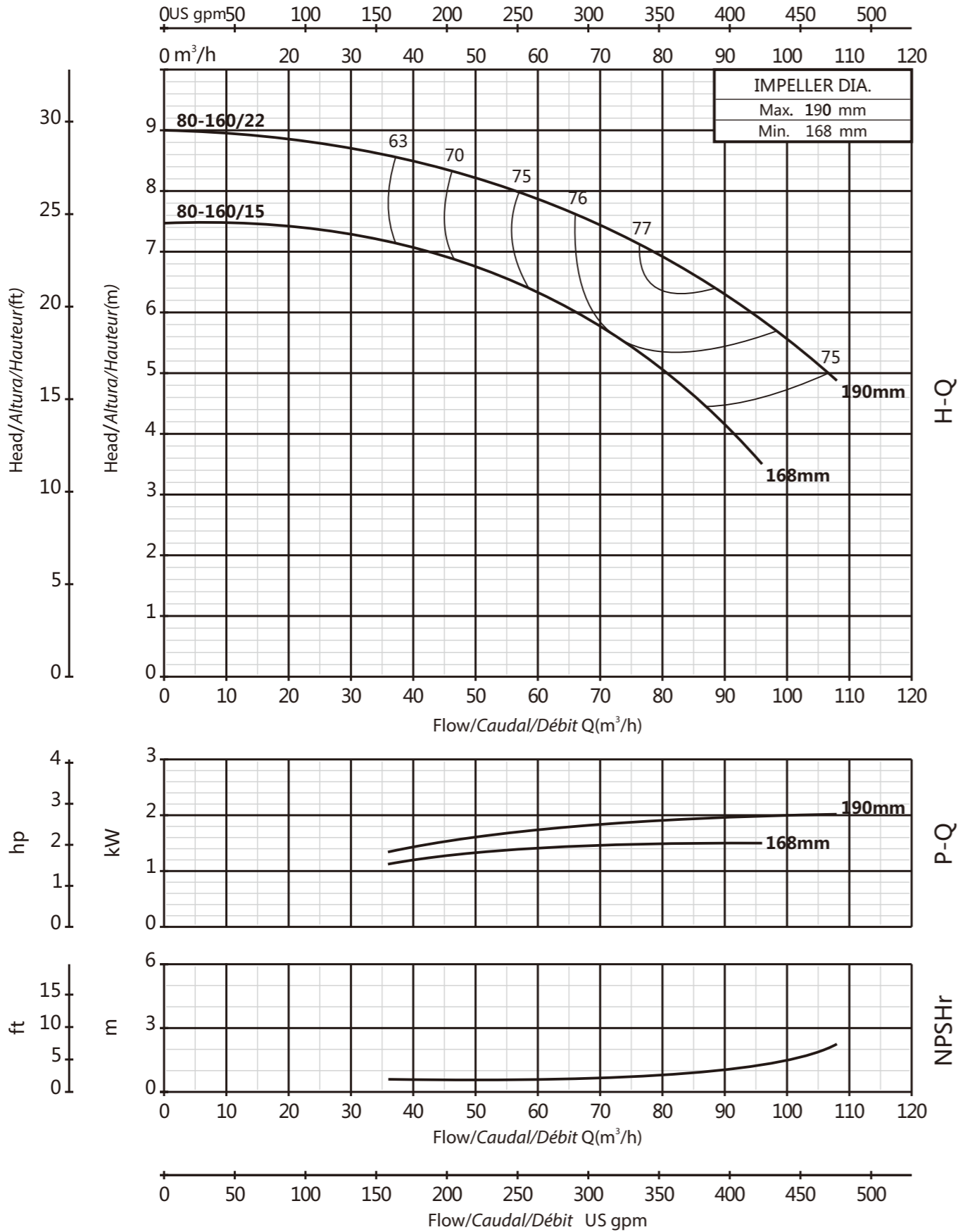

80-200

1450rpm

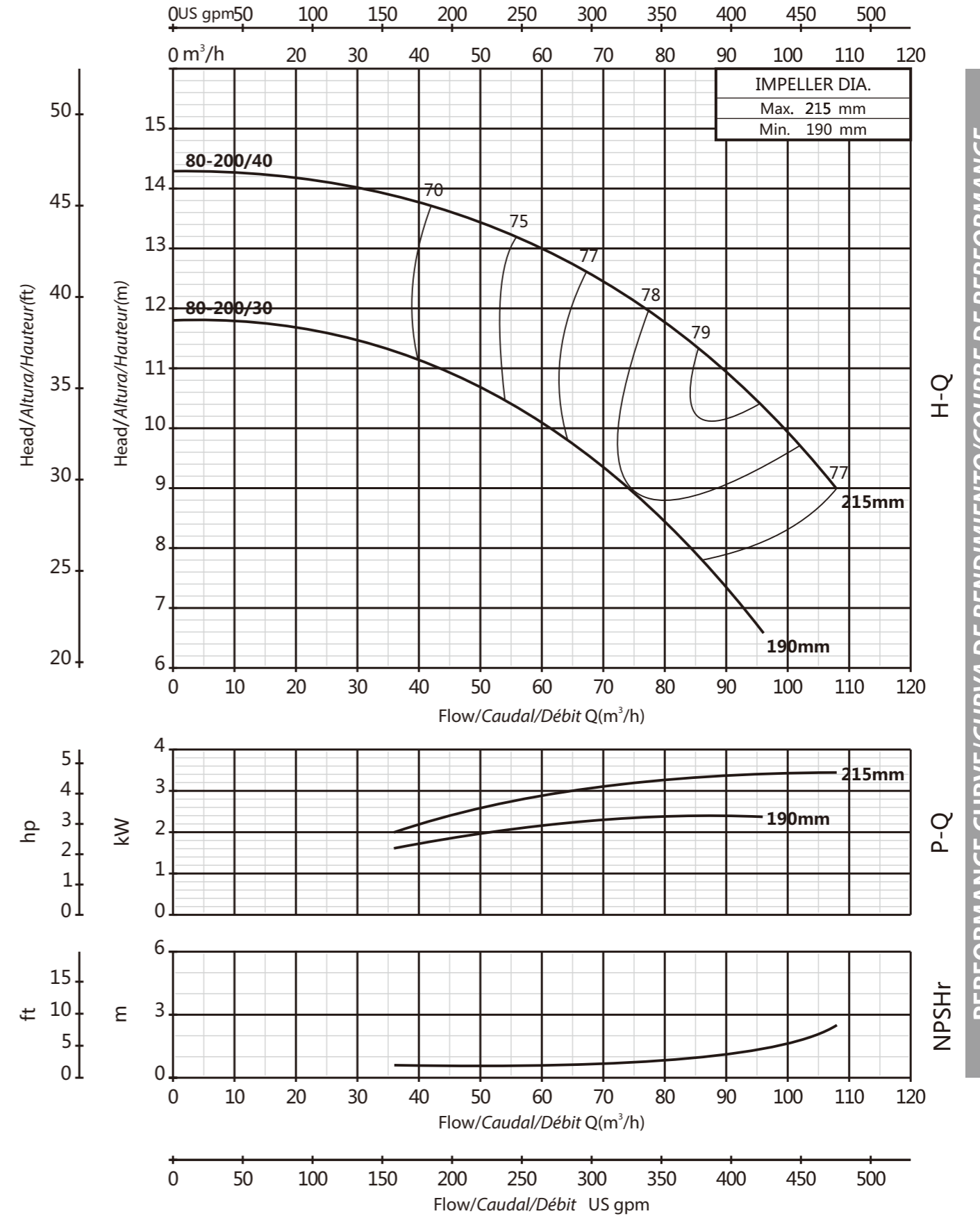

PERFORMANCE CURVE/CURVA DE RENDIMIENTO/COURBE DE PERFORMANCE

PERFORMANCE CURVE/CURVA DE RENDIMIENTO/COURBE DE PERFORMANCE

80-250

1450rpm

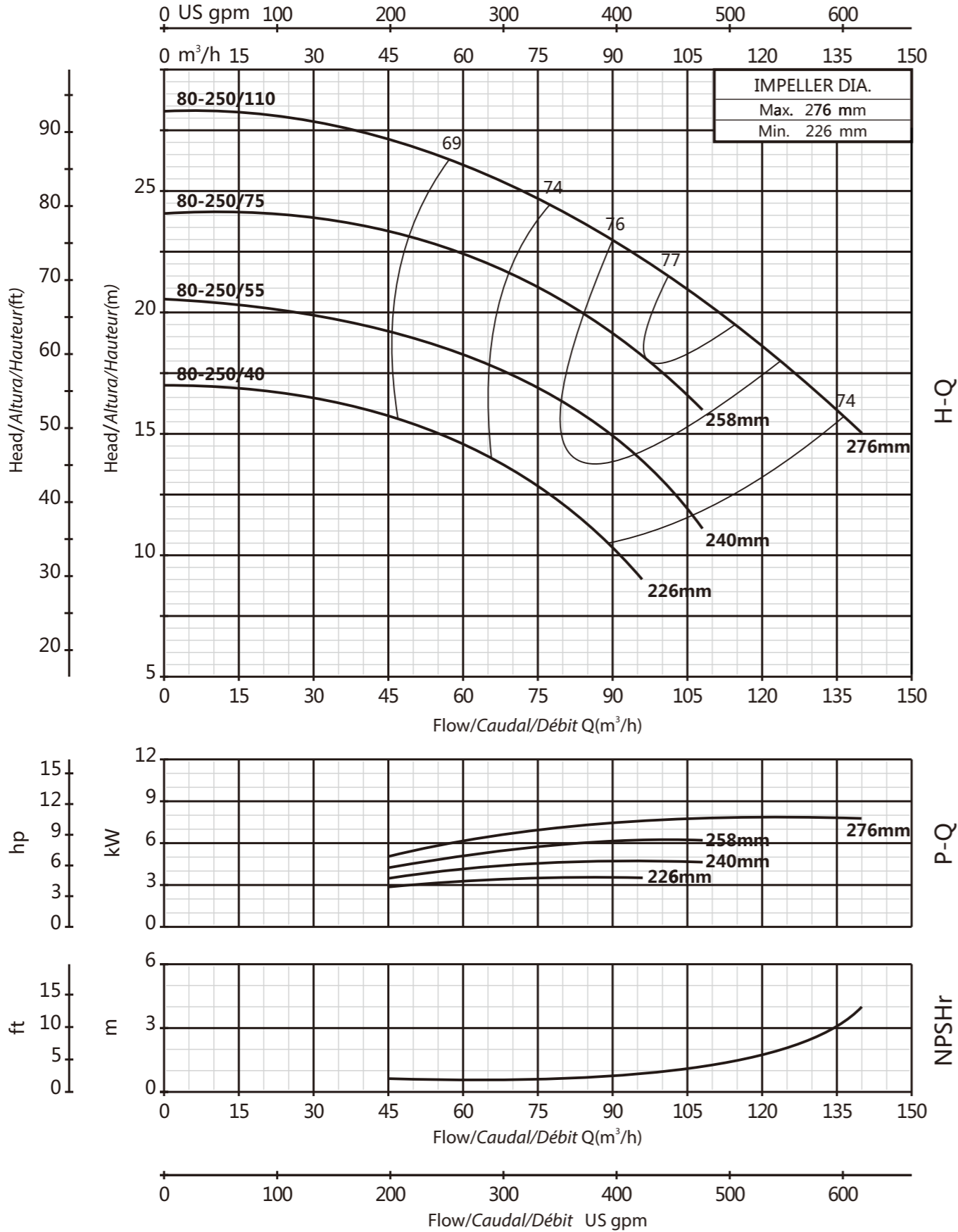

PERFORMANCE CURVE/CURVA DE RENDIMIENTO/COURBE DE PERFORMANCE

80-315

1450rpm

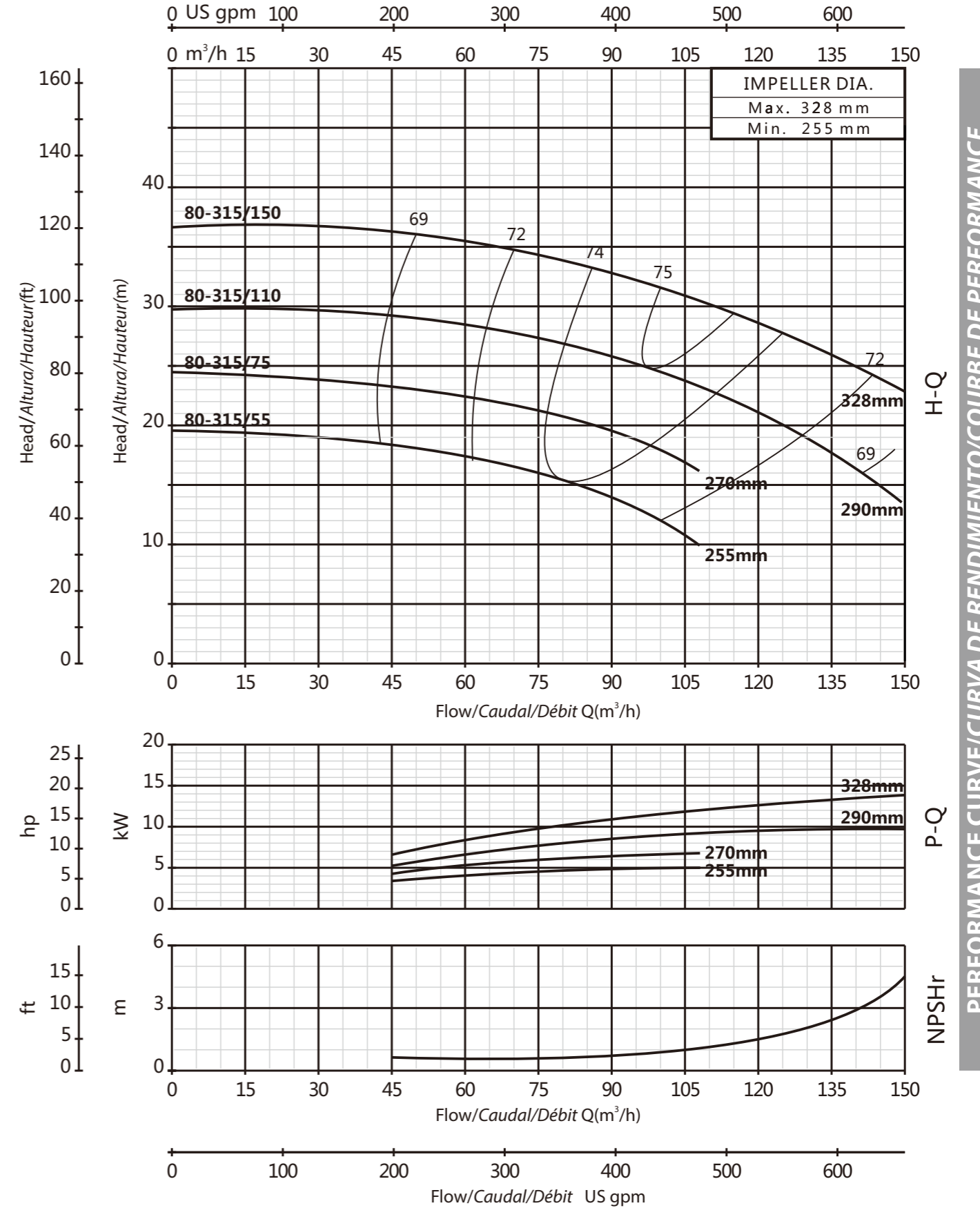

PERFORMANCE CURVE/CURVA DE RENDIMIENTO/COURBE DE PERFORMANCE

80-400

1450rpm

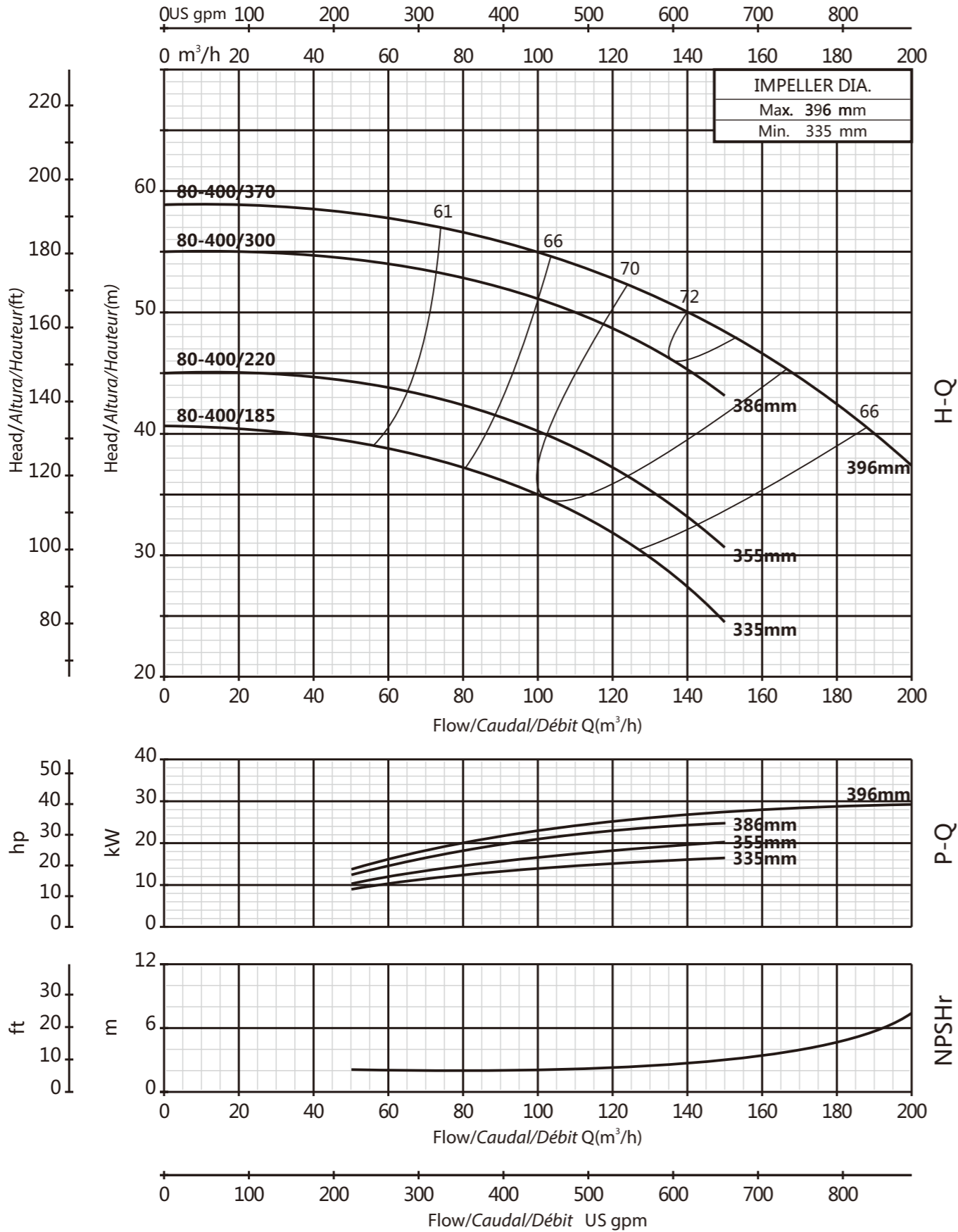

100-160

1450rpm

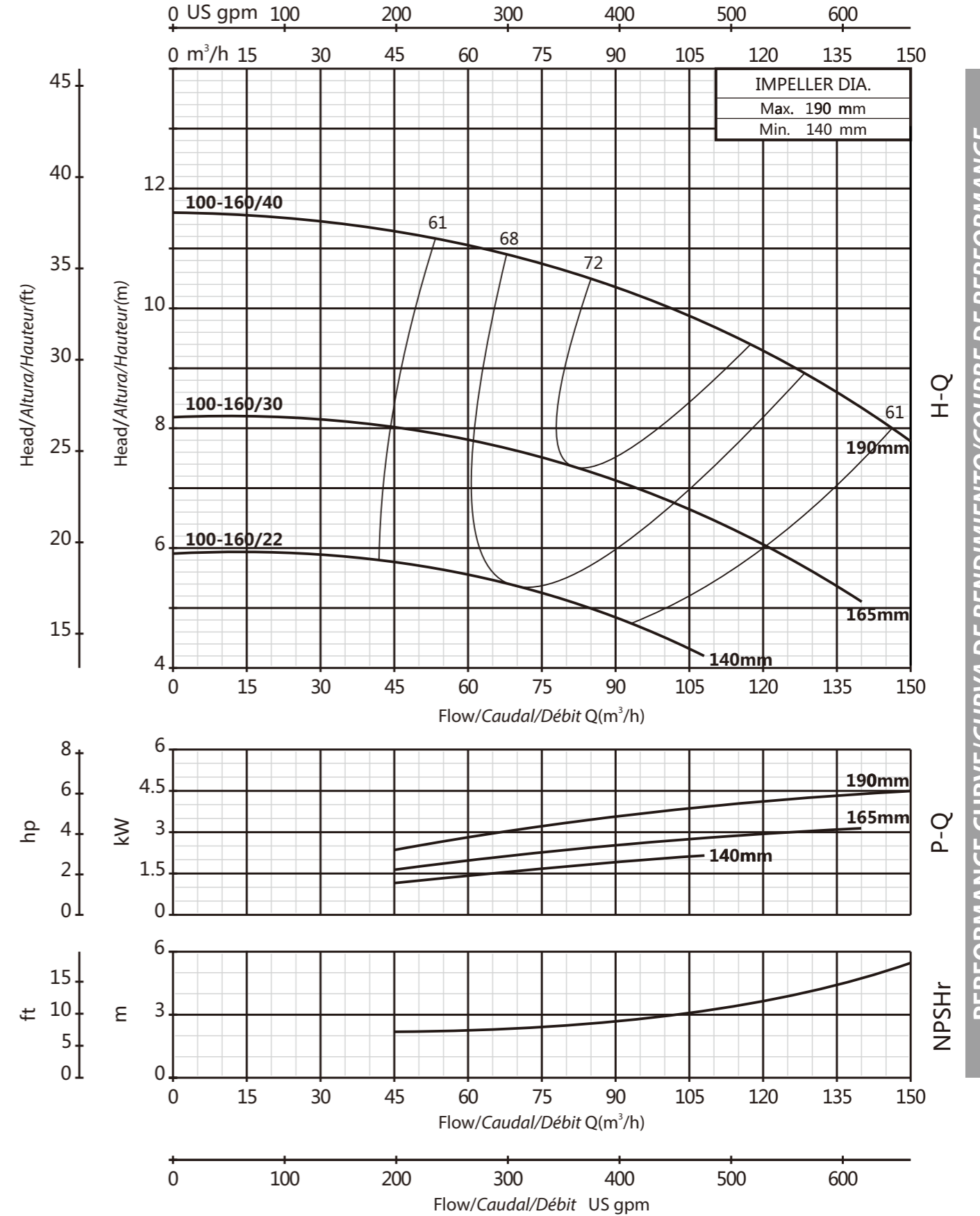

PERFORMANCE CURVE/CURVA DE RENDIMIENTO/COURBE DE PERFORMANCE

PERFORMANCE CURVE/CURVA DE RENDIMIENTO/COURBE DE PERFORMANCE

100-200

1450rpm

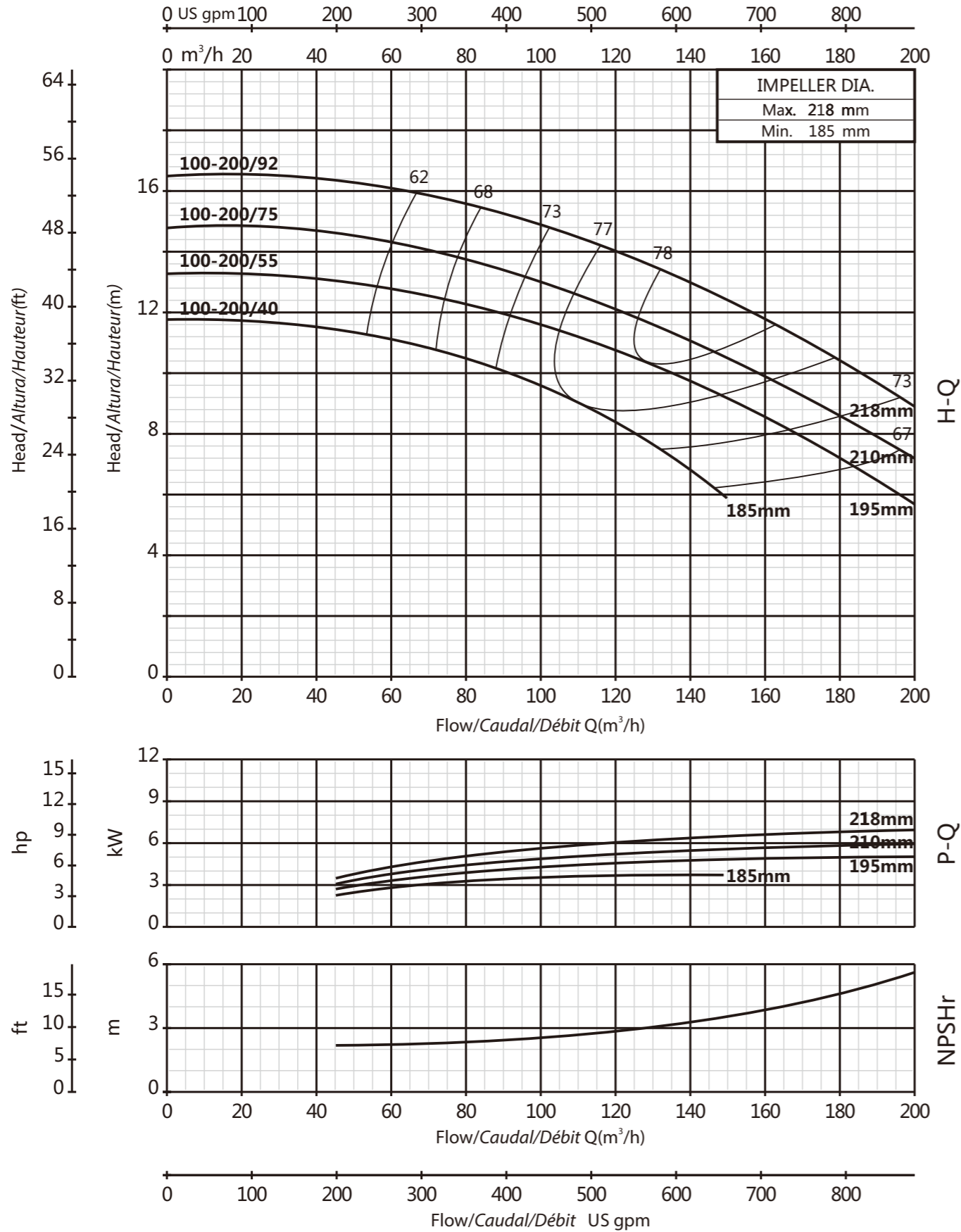

100-250

1450rpm

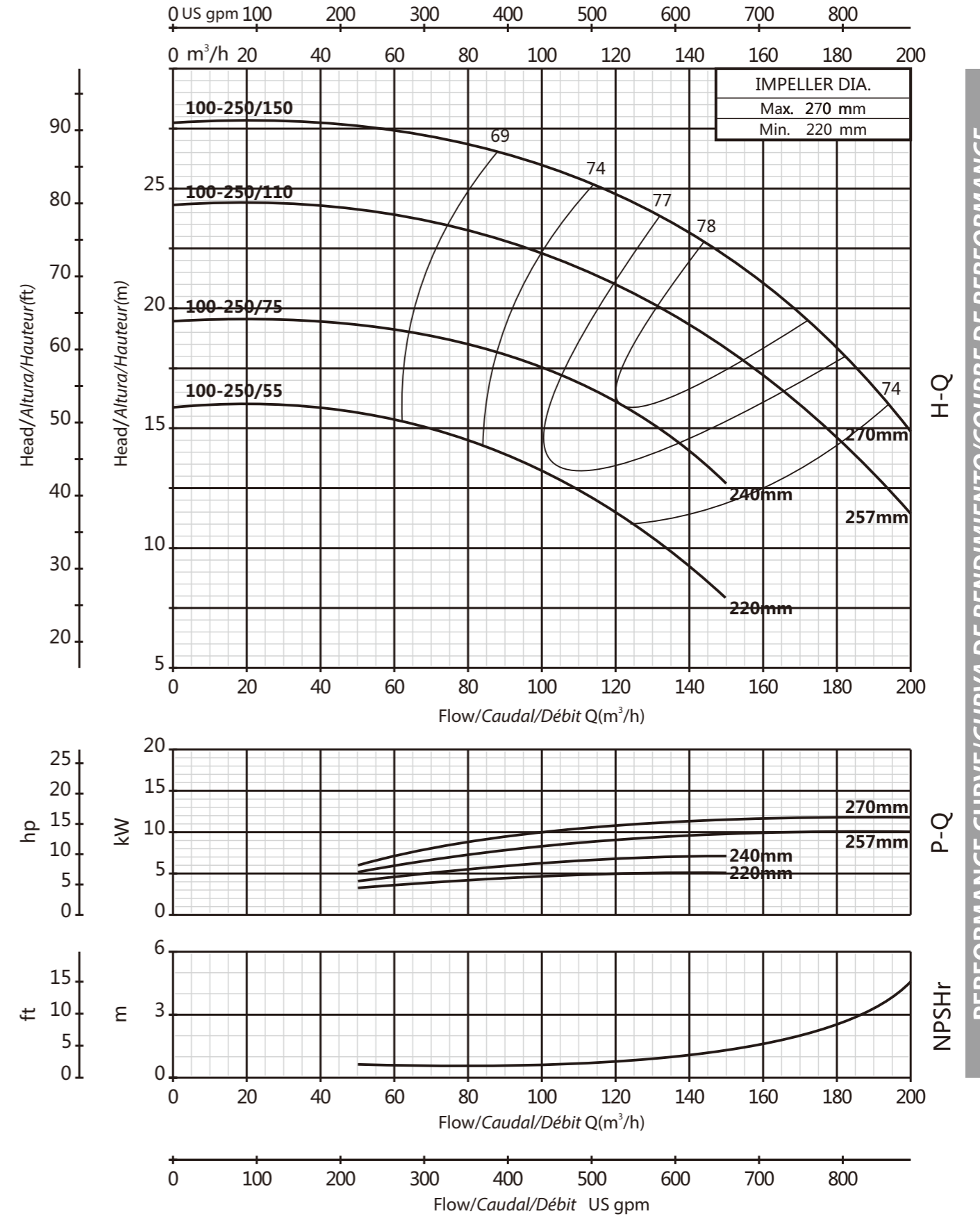

PERFORMANCE CURVE/CURVA DE RENDIMIENTO/COURBE DE PERFORMANCE

PERFORMANCE CURVE/CURVA DE RENDIMIENTO/COURBE DE PERFORMANCE

100-315

1450rpm

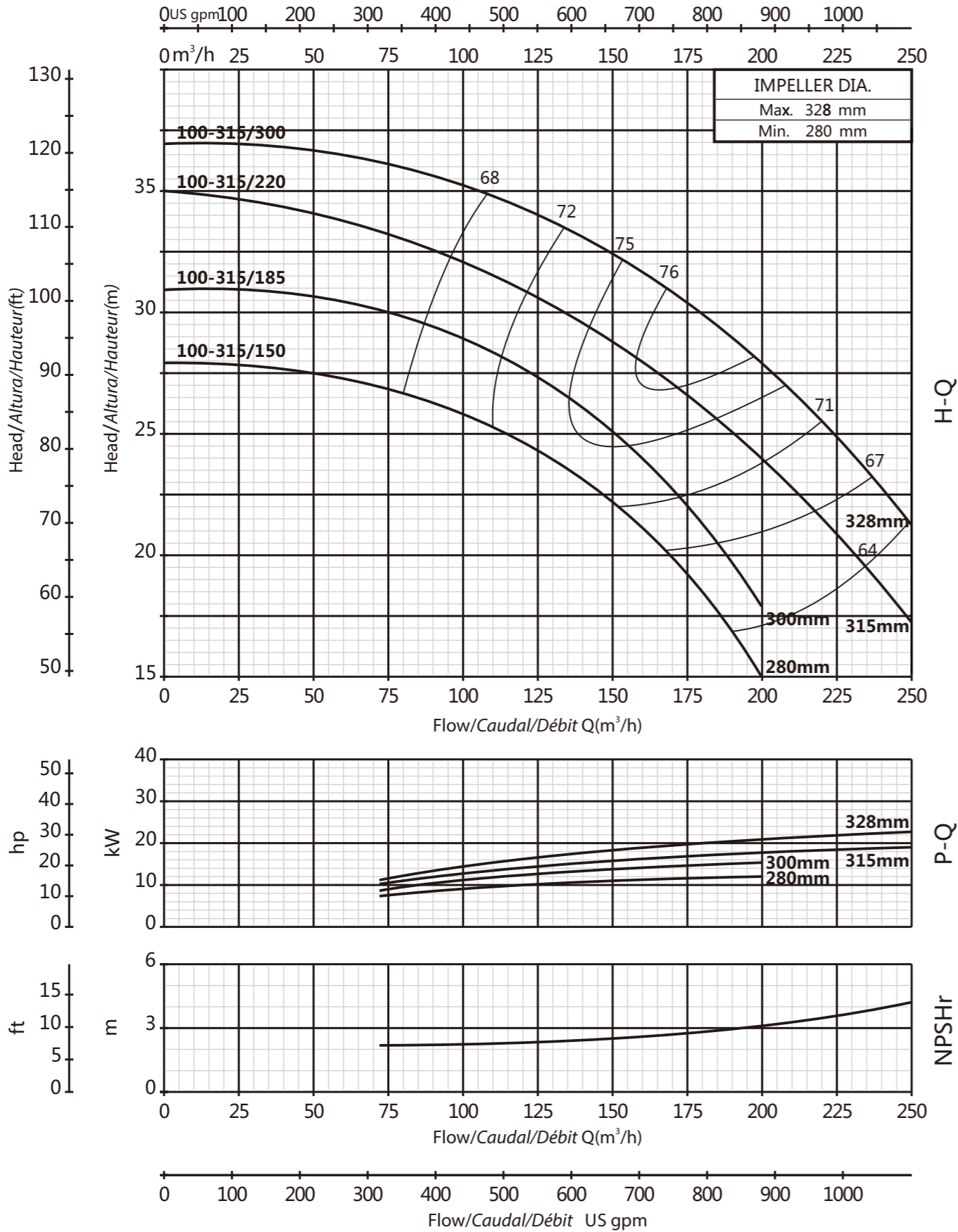

100-400

1450rpm

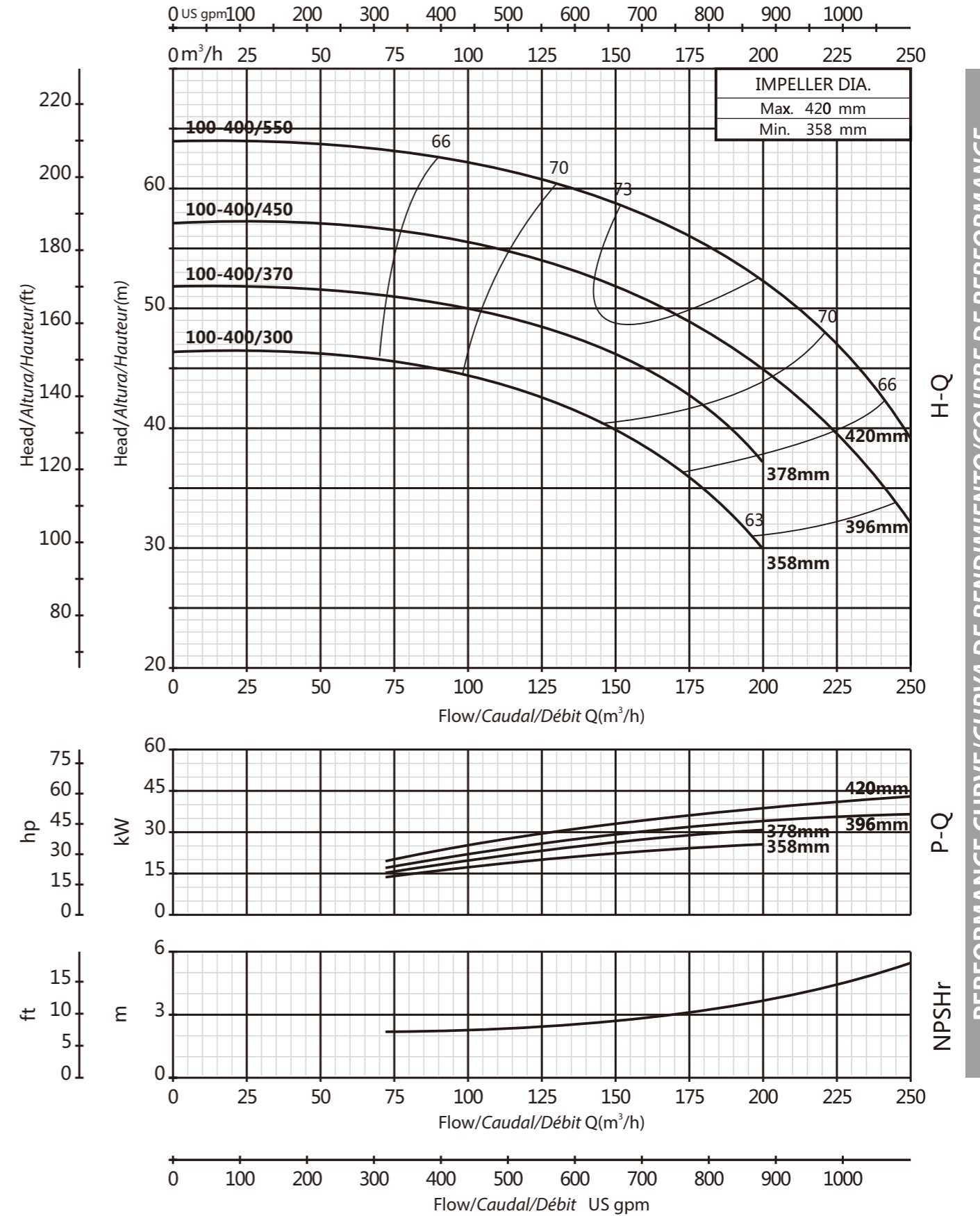

PERFORMANCE CURVE/CURVA DE RENDIMIENTO/COURBE DE PERFORMANCE

PERFORMANCE CURVE/CURVA DE RENDIMIENTO/COURBE DE PERFORMANCE

125-200

1450rpm

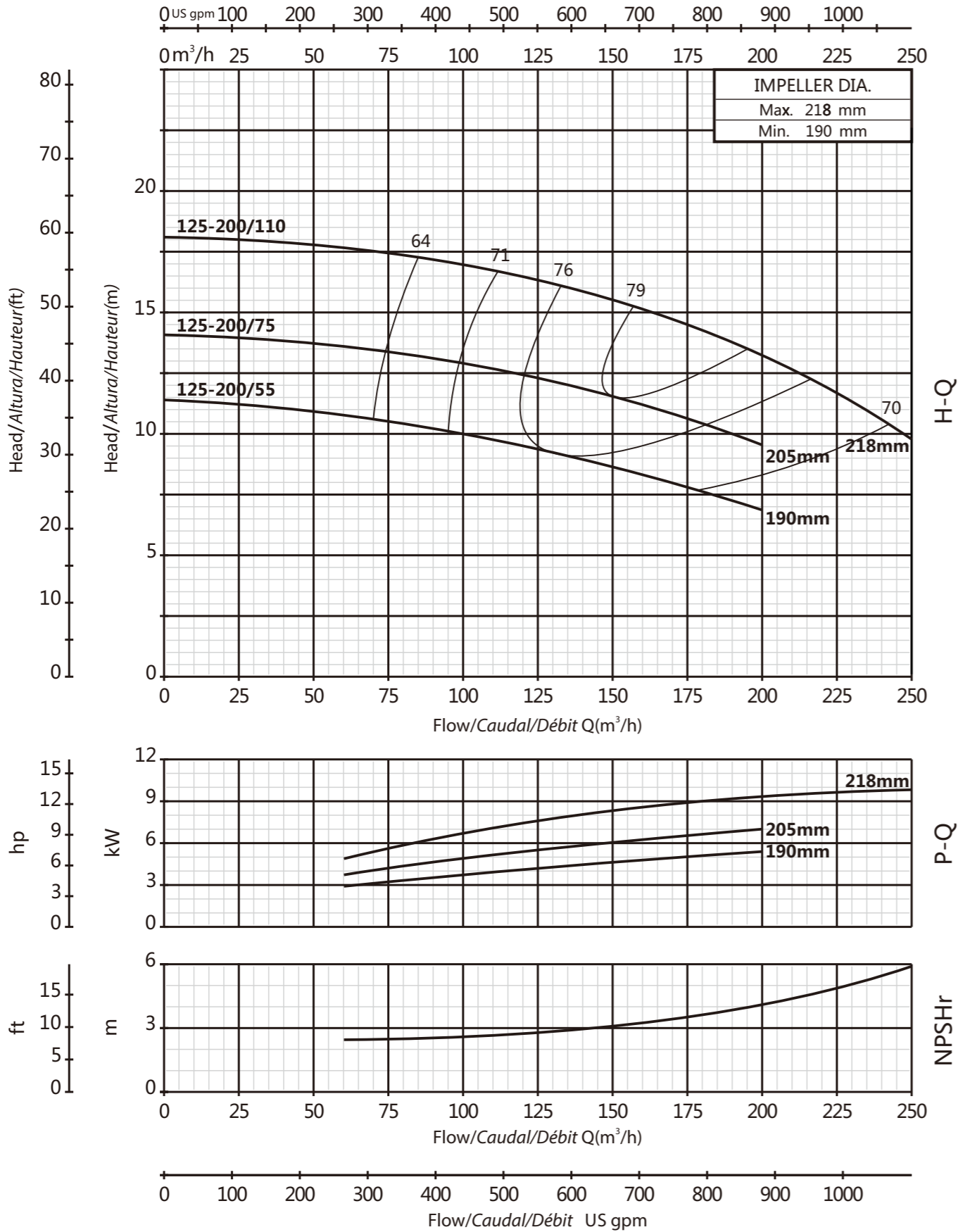

125-250

1450rpm

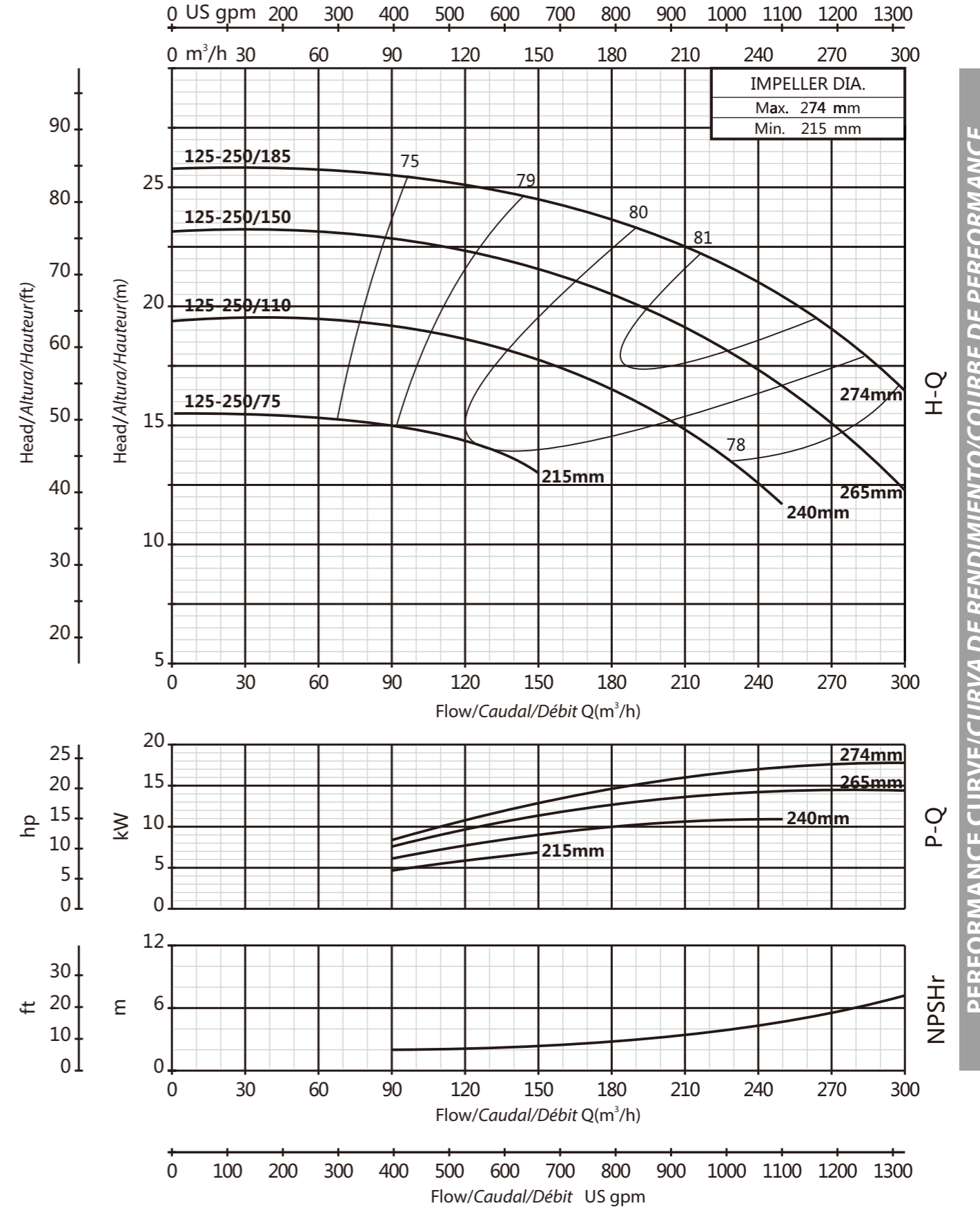

PERFORMANCE CURVE/CURVA DE RENDIMIENTO/COURBE DE PERFORMANCE

PERFORMANCE CURVE/CURVA DE RENDIMIENTO/COURBE DE PERFORMANCE

125-315

1450rpm

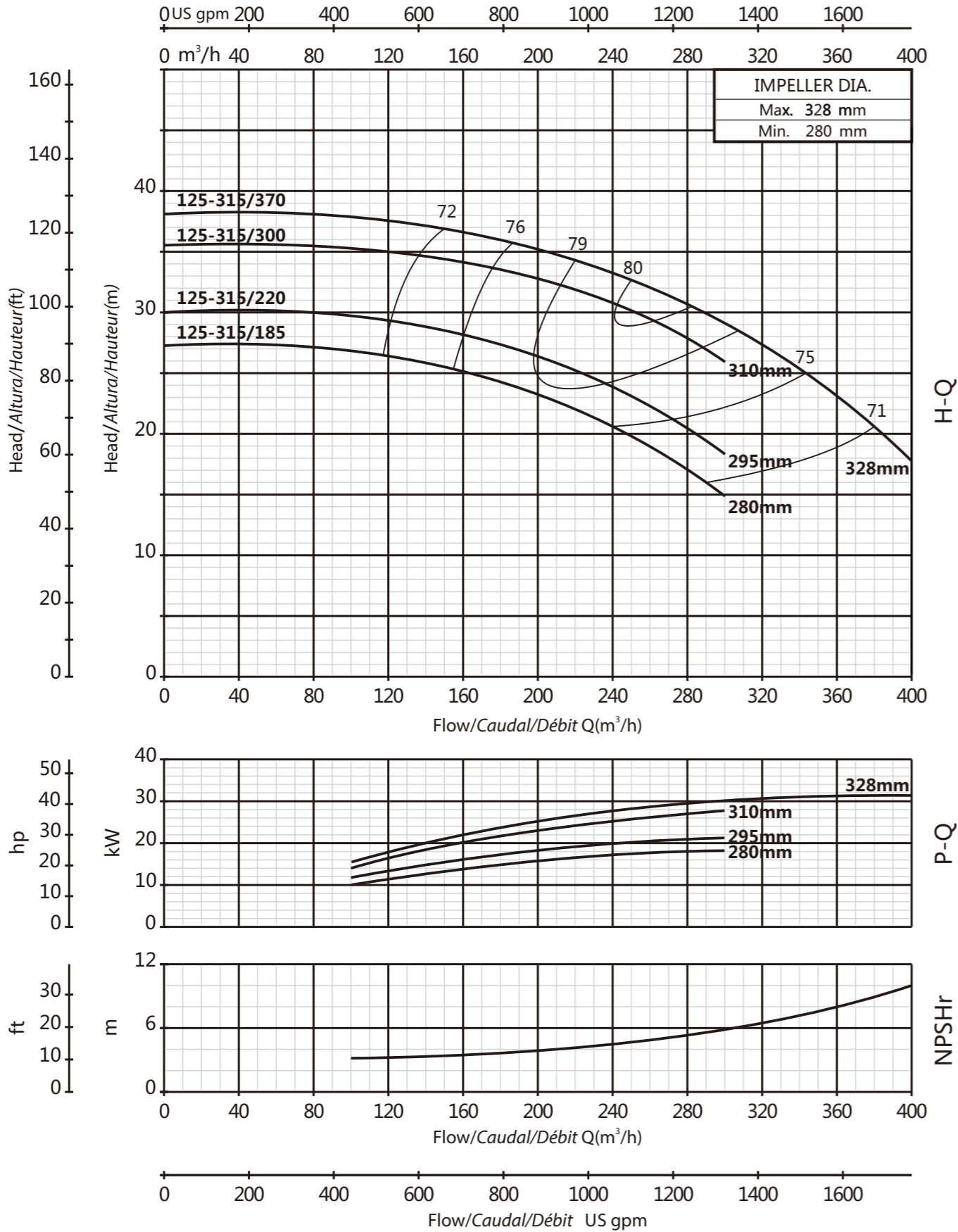

125-400

1450rpm

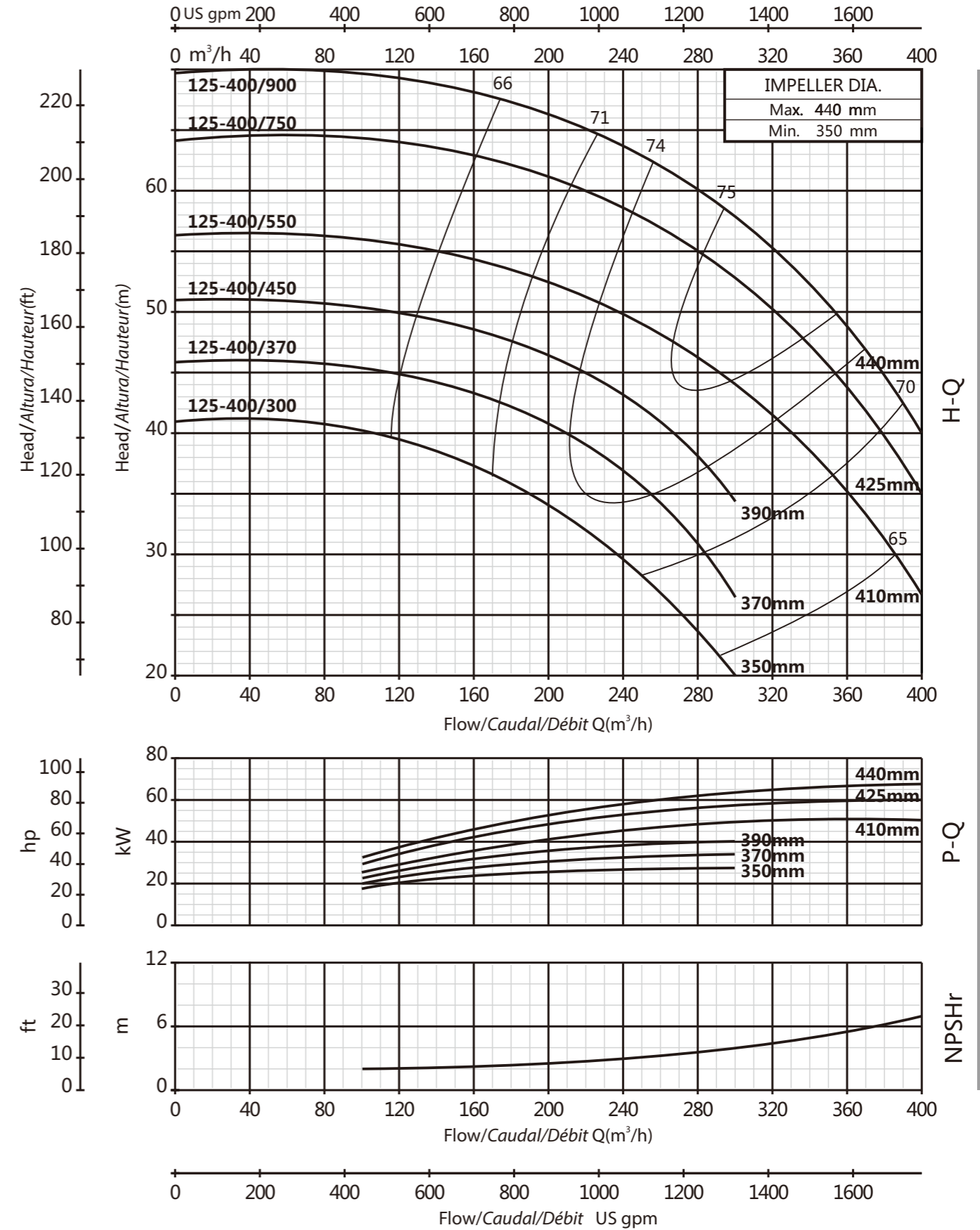

PERFORMANCE CURVE/CURVA DE RENDIMIENTO/COURBE DE PERFORMANCE

PERFORMANCE CURVE/CURVA DE RENDIMIENTO/COURBE DE PERFORMANCE

150-200

1450rpm

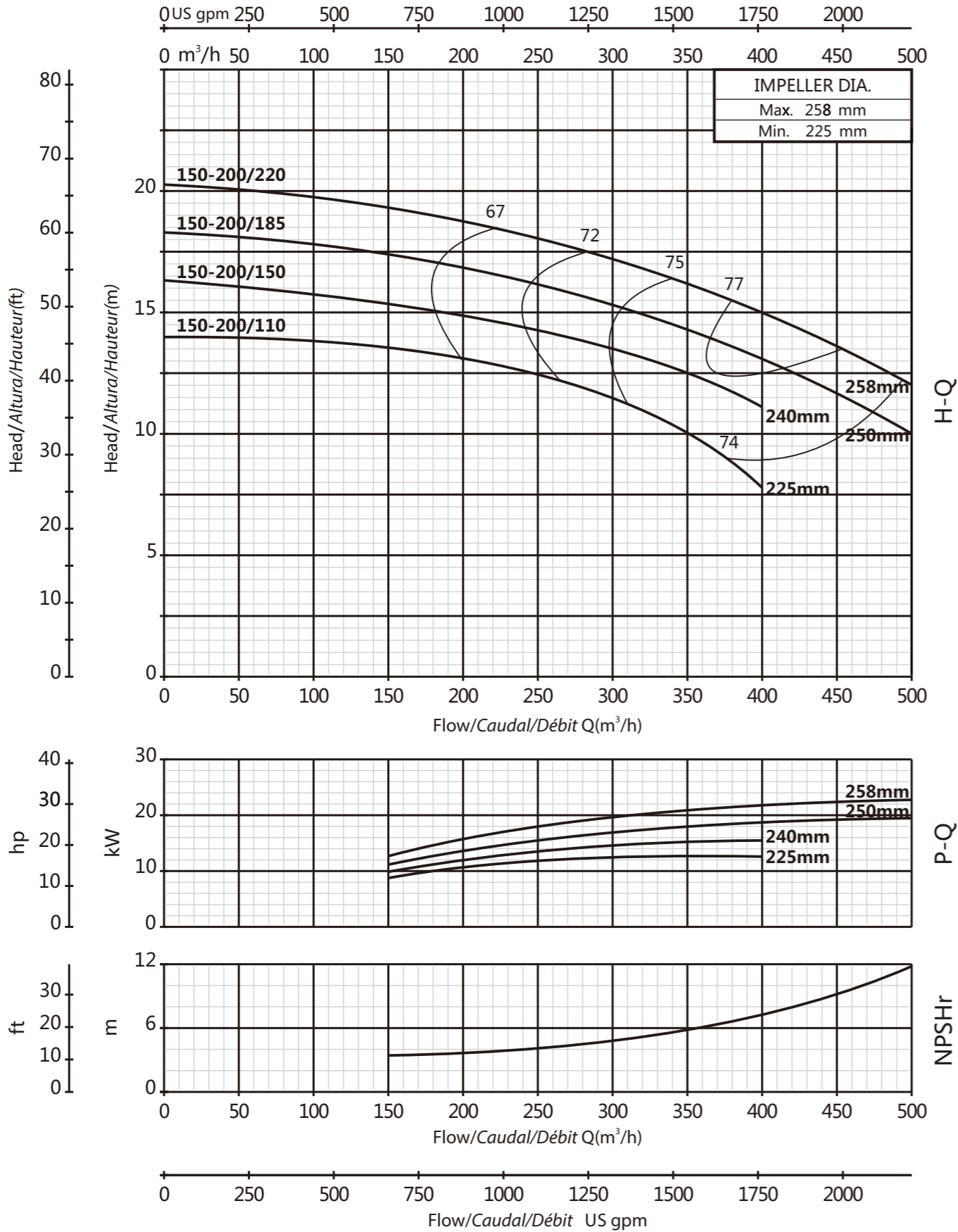

150-250

1450rpm

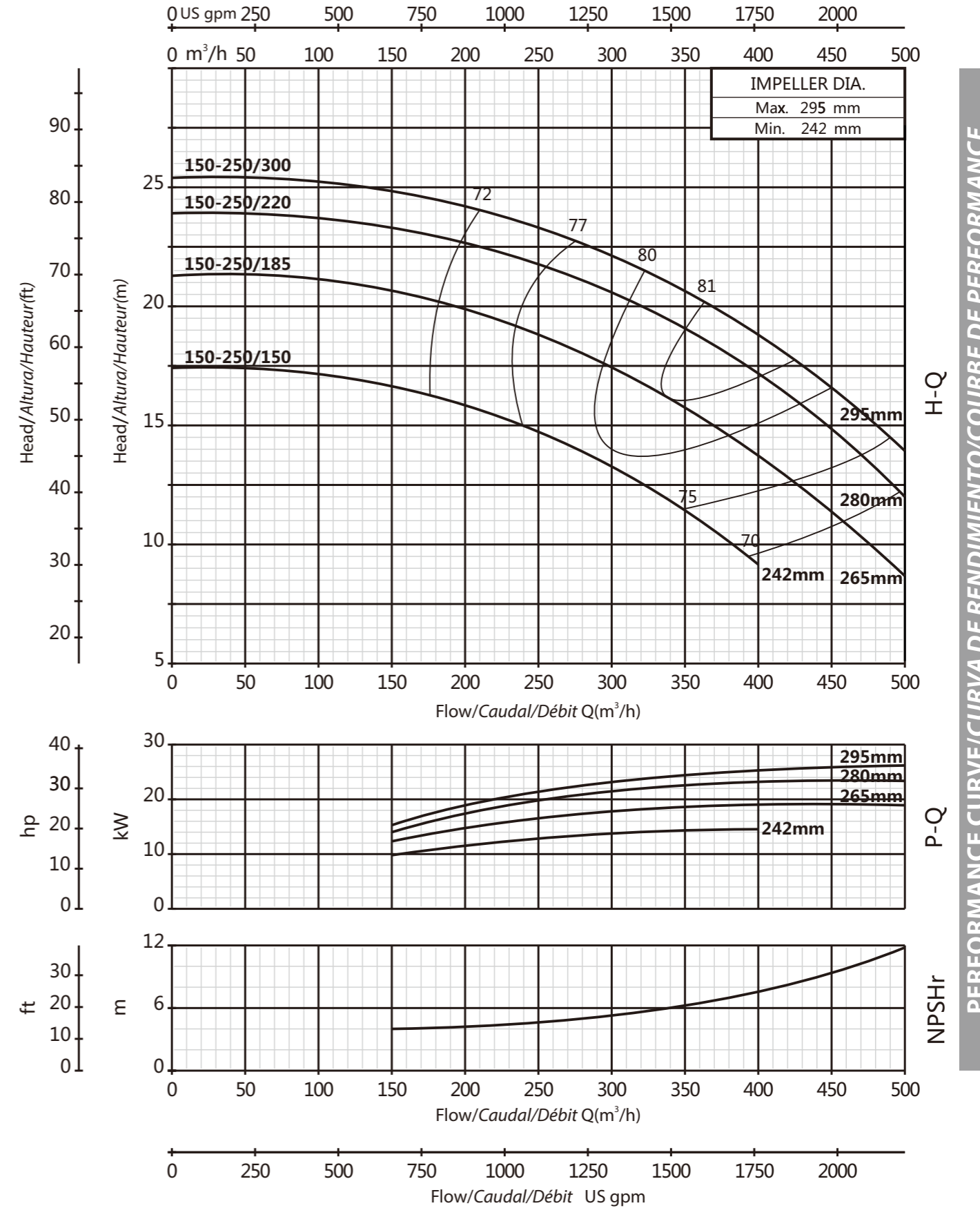

PERFORMANCE CURVE/CURVA DE RENDIMIENTO/COURBE DE PERFORMANCE

PERFORMANCE CURVE/CURVA DE RENDIMIENTO/COURBE DE PERFORMANCE

150-315

1450rpm

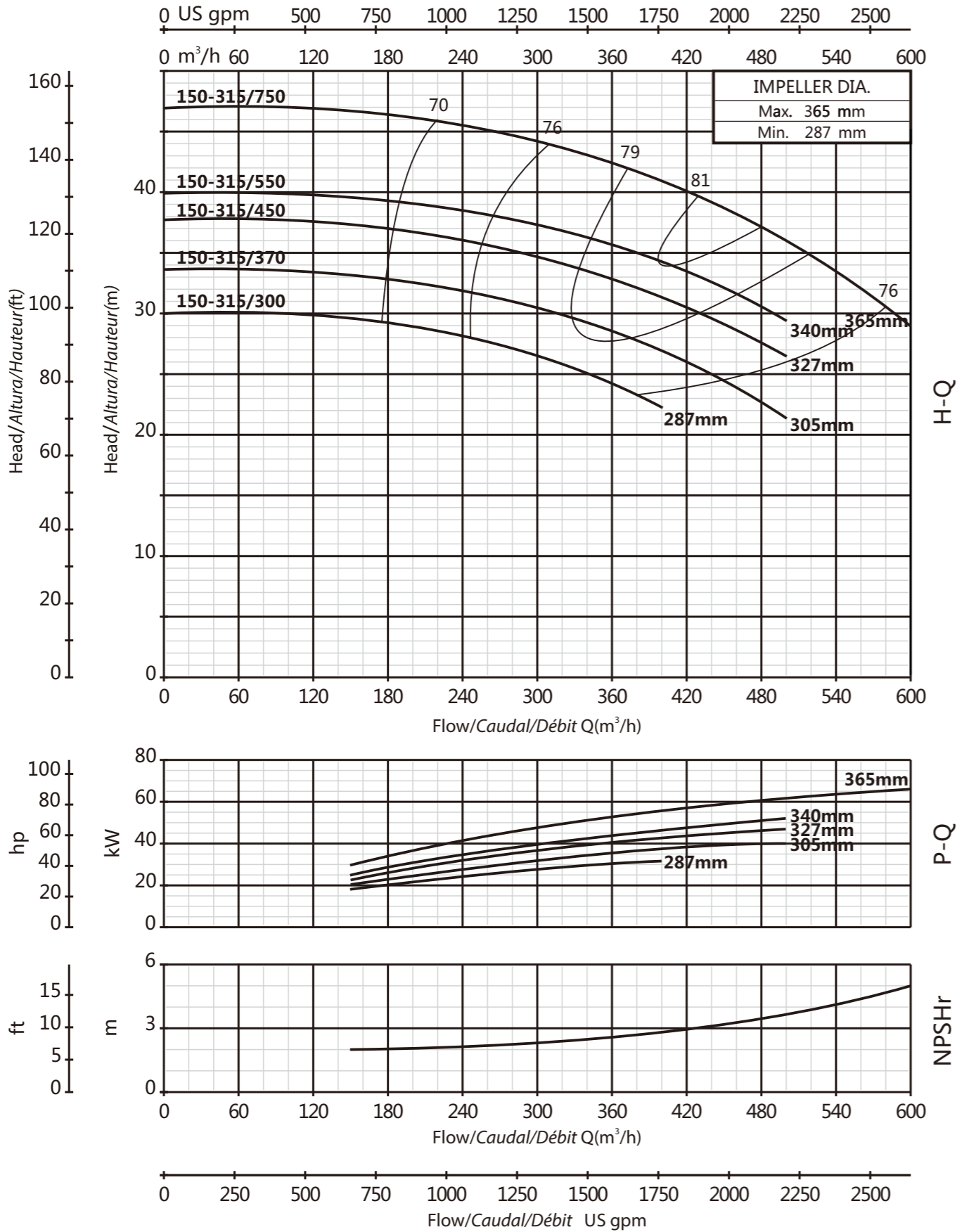

150-400

1450rpm

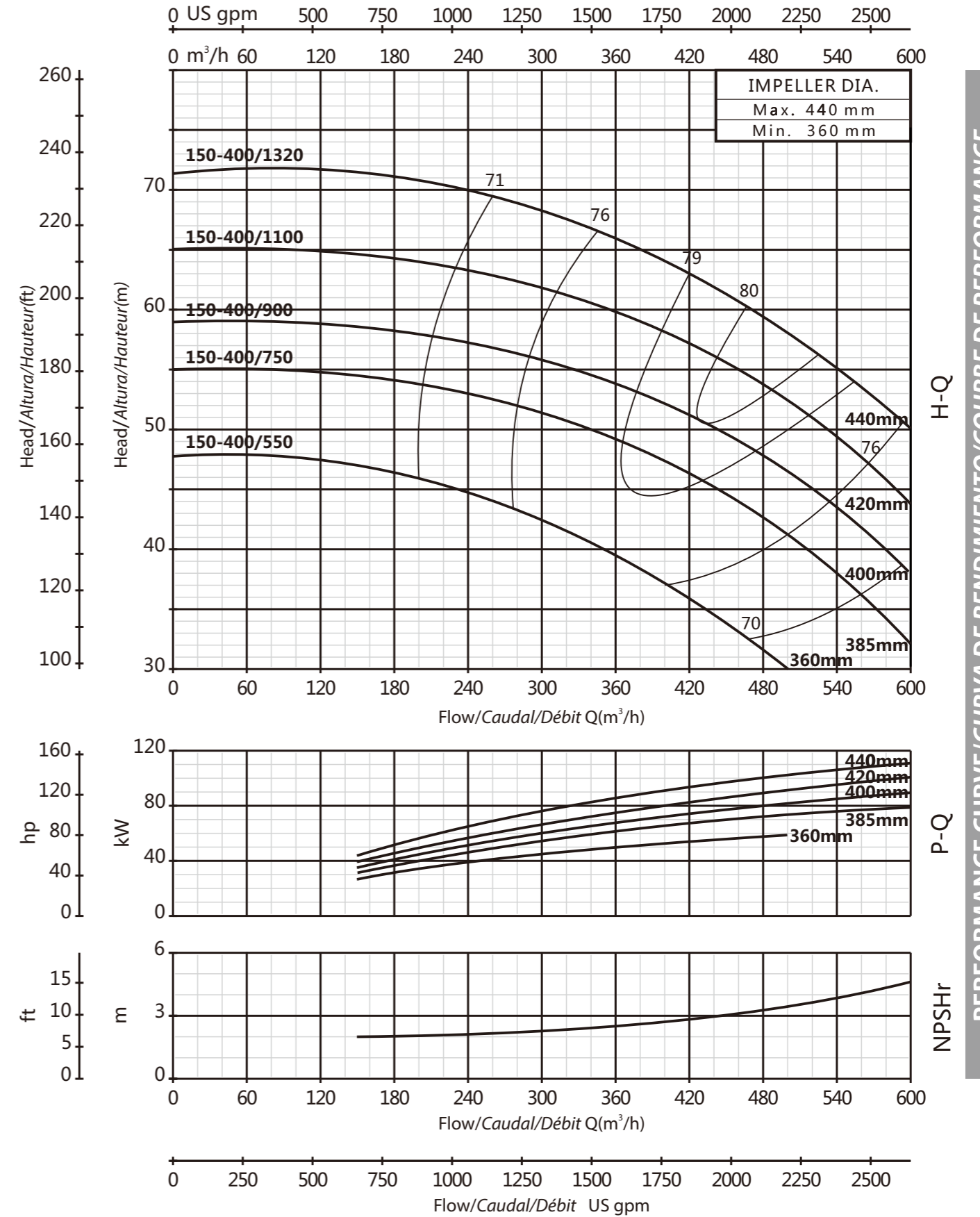

PERFORMANCE CURVE/CURVA DE RENDIMIENTO/COURBE DE PERFORMANCE

PERFORMANCE CURVE/CURVA DE RENDIMIENTO/COURBE DE PERFORMANCE

200-250

1450rpm

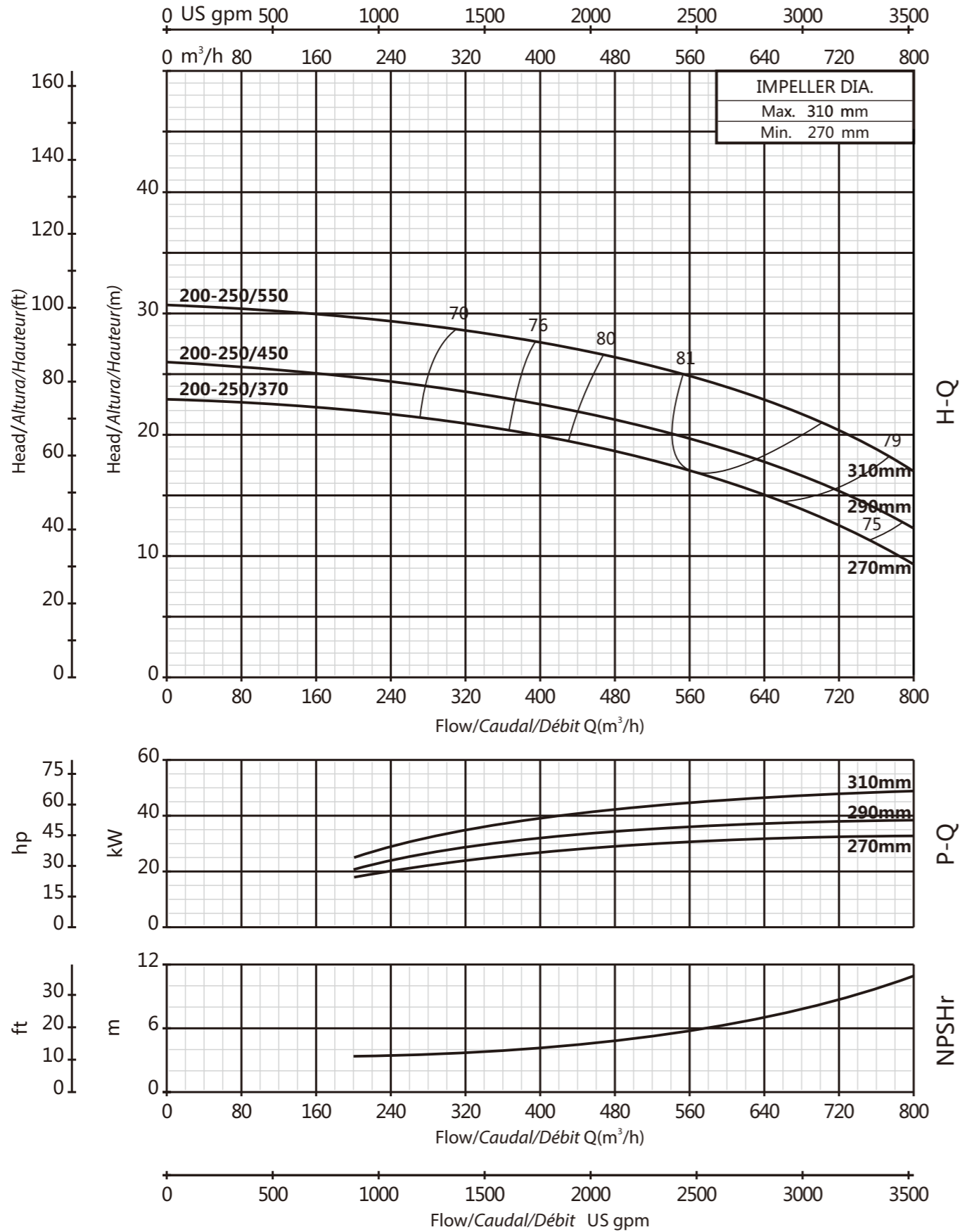

200-315

1450rpm

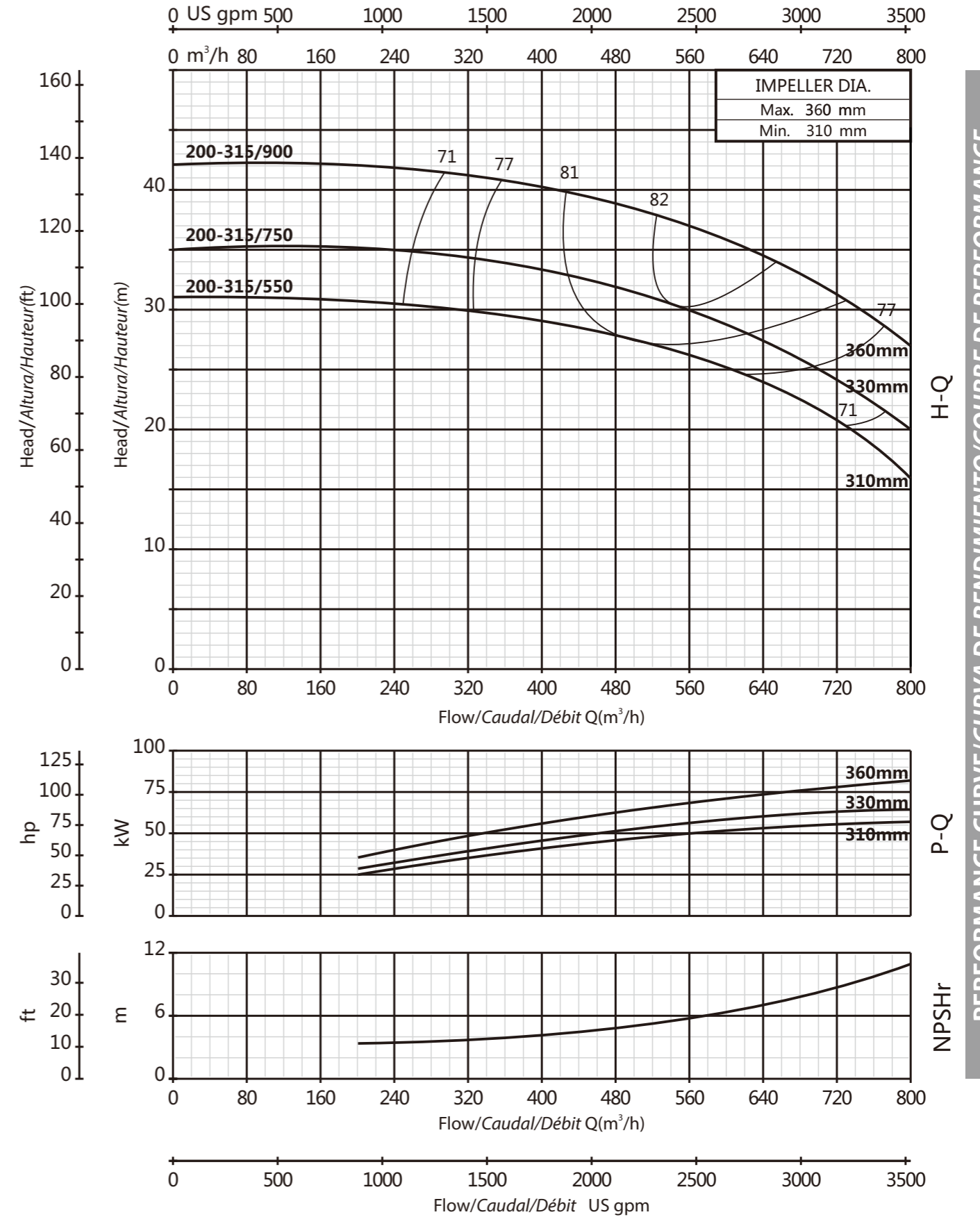

PERFORMANCE CURVE/CURVA DE RENDIMIENTO/COURBE DE PERFORMANCE

PERFORMANCE CURVE/CURVA DE RENDIMIENTO/COURBE DE PERFORMANCE

200-400 1450rpm

250-315 1450rpm

PERFORMANCE CURVE/CURVA DE RENDIMIENTO/COURBE DE PERFORMANCE

PERFORMANCE CURVE/CURVA DE RENDIMIENTO/COURBE DE PERFORMANCE

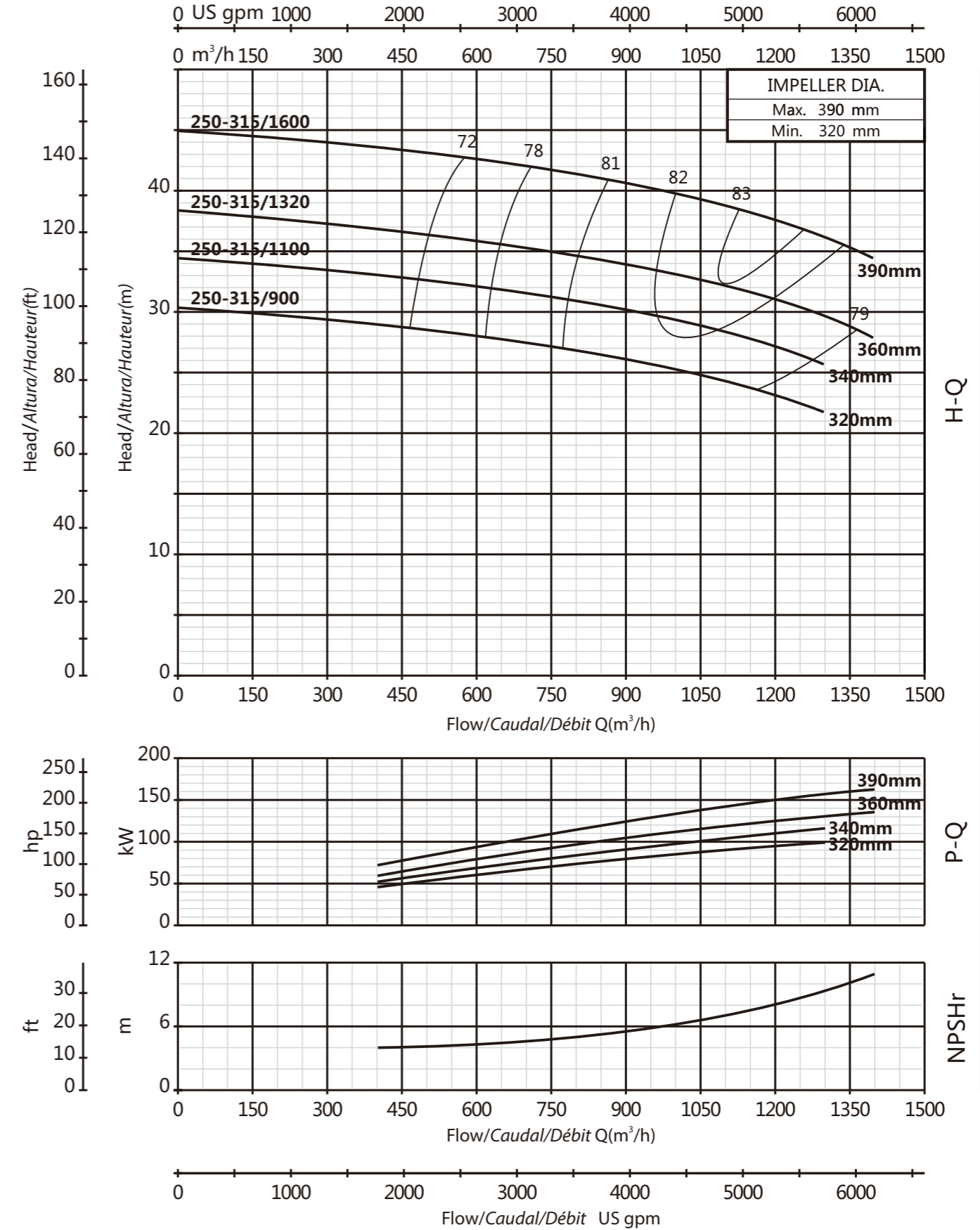
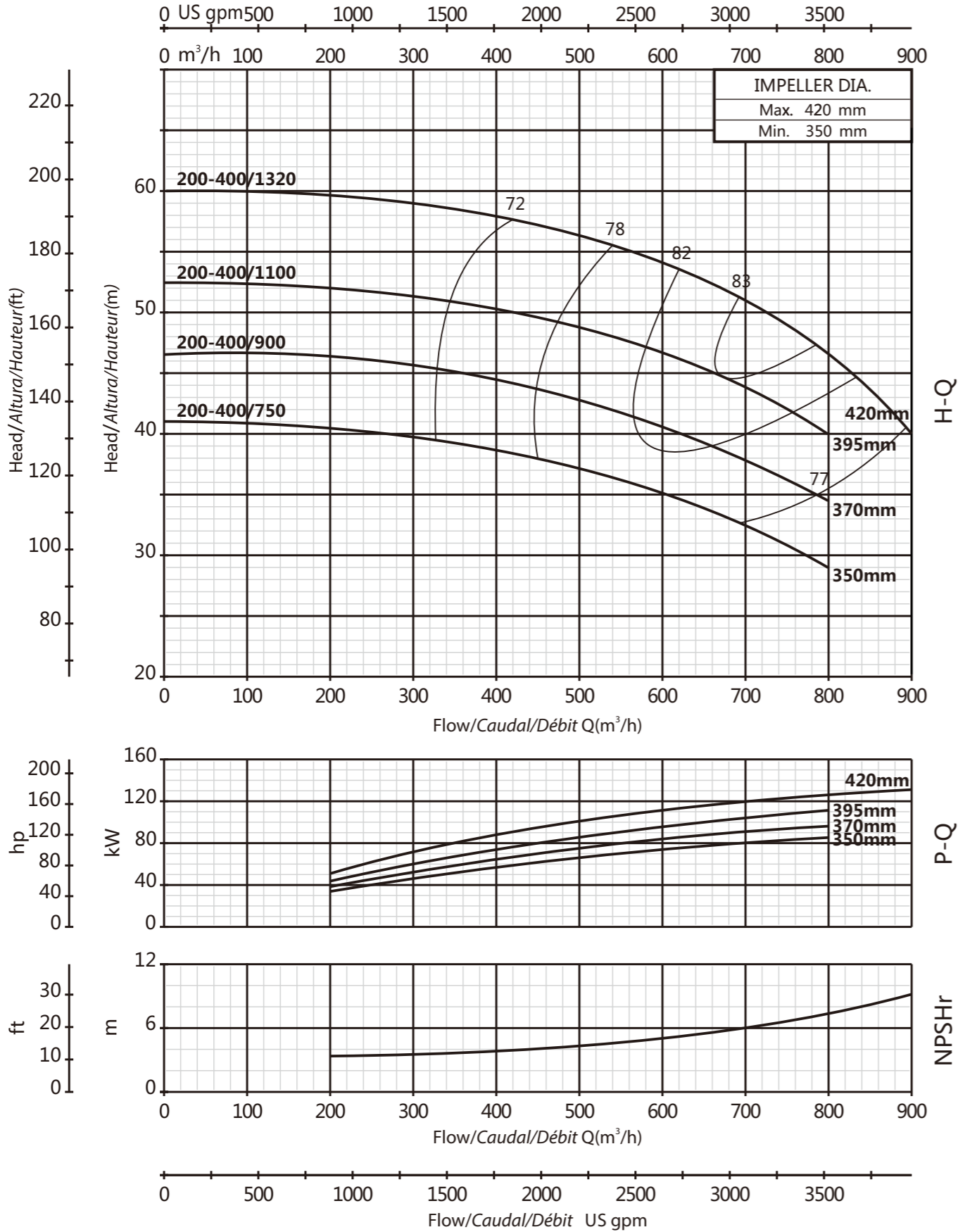

250-400

1450rpm

PERFORMANCE CURVE/CURVA DE RENDIMIENTO/COURBE DE PERFORMANCE

